



NB IoT – Cat-M1 Low Power Ultrasonic Distance and Level Sensor

- Compatible with most standard communication Protocols (UDP, LwM2M, MQTT, NIDD, etc.)
- Wide range of industrial applications
- High accuracy and repeatability
- Designed to meet outdoor applications
- Long-term durable performance in harsh environment
- Ultra-low power
- Suitable for liquid and solid media



TECHNICAL SPECIFICATION

Sensor

• Range:	5,10	m
• Accuracy: (combined linearity, hysteresis, repeatability)	±1 (typ.)	%Span
• Resolution:	1	mm
• Sensor Minimum Distance:	0 ~ 20cm for 5m range 0 ~ 50cm for 10m range	
• Reading-to-reading stability:	1mm in 1m (Typ)	
• Compensated Temperature:	-10 ~ +65	°C

Power

• Power Supply:	Built-in Replaceable Lithium Battery, External Power (option)	
• Rated Voltage	3.6	V
• Battery Lifetime:	50,000+ readings and 10,000+ transmission (With UDP protocol/ More than 10 years for most applications)	

Physical Specification

• Materials:	Enclosure: ASA/POM	
• Weight:	~500	g
• Protection Rate:	IP66	-

Communication

• SIM Card Type	4FF Nano-SIM, from any Network Provider	
• Firmware Update:	Over The Air, Locally via Wireless Connectivity	
• Sampling Period:	Configurable via downlink (default 4 hours)	
• Power Consumption:	Power Saving: < 5uA, Transmission: < 220mA	

• Communication Standards	Cat-NB1 (NB-IoT) Cat-M1 (option of back support by GPRS)
• Communication Bands	B1/B2/B3/B4/B5/B8/B12/B13/B18/B19/B20/B26/B28 and B39
• Data Rates:	Cat-M1: 375Kbps (DL)/375Kbps (UL) NB-IoT: 32Kbps (DL)/70Kbps (UL)
• TX Power:	23dBm
• Min Receiver Sensitivity:	Cat-M1: -107dBm NB-IoT: -113dBm
• Antenna:	Internal (Default)/ External (customised options available)
• Optional Features:	<ul style="list-style-type: none"> • Attach without PDN (Packet Data Network) • Support for IPV6 • SMS communication • Mobility support (Cat-M1 only)

NETWORK CONNECTION AND VISUALISATION

Network Integration

Pre-configured or configurable to all main narrow band networks (3, A1, AT&T, China Mobile, DU, Etisalat, KPN, M1 Singapore, Optus, Orange, Proximus, Spark, Sprint, Swisscom, Telefonica, Telstra, T-Mobile, Verizon, Vodafone, 1NCE, Emnify and any other network)

Visualisation and Data Management

Ellenex white label microservice platform and Integratable to all main IIoT platforms directly or through the API(AWS, Azure, PTC ThingWorx, Bosch IoT, Cisco Jasper & Kinetic, Sierra Numerex, MathWorks ThingSpeak, GE Digital Predix, LandisGyr, Siemens MindSphere, Cumulocity, myDevices, Ubidots, TagoIO, AllThingsTalk Maker, HPE IoT and any other major IoT platform).

Ellenex Platform Main Features

- Encrypted ultra-low power communication protocol
- Advanced device inventory
- Integration APIs for enterprise systems
- Multi-tenant role-based access control
- Data export and import
- White-label platform for enterprise runs on private account
- Variable alarm setting for high and low thresholds and multi-channel alerting
- Sampling and transmission interval configuration
- Transmission condition configuration
- Other configurations and customisation available on request



Encrypted & ultra-low power



Integratable



Dynamic alerting



Multi-tenant



Scalable

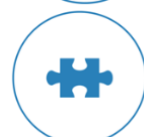

Composable & API first

DUS2-N Spec-sheet



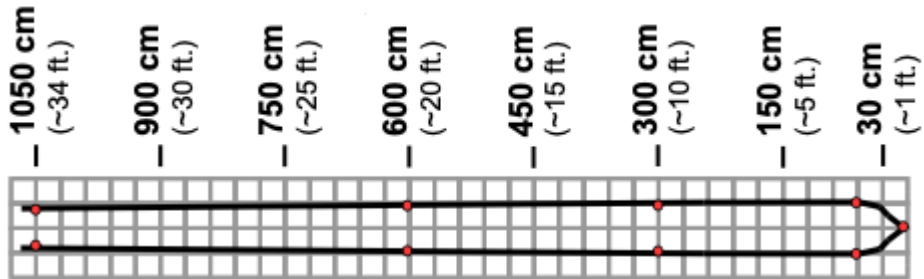

Beam pattern

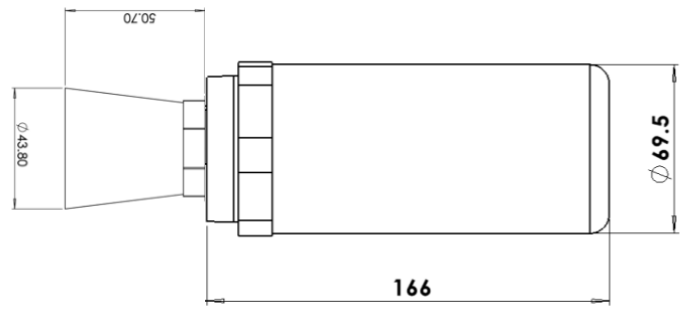

Typical beam patter for 30cm target mover left and right with the board parallel to the sensor face

MODEL GUIDE

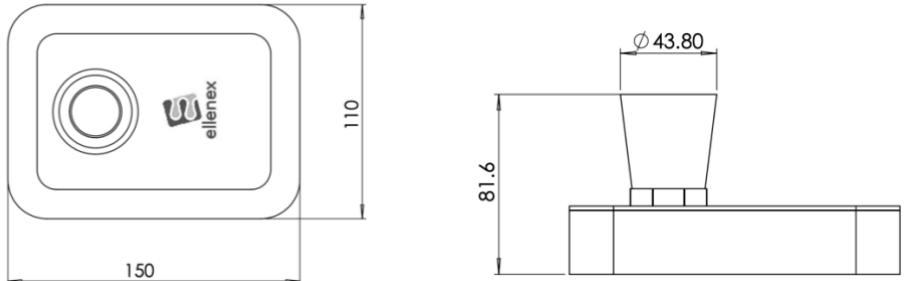
Model	Options:
<p>C Model:</p> 	 <p>Cylindrical compact, POM enclosure</p>
<p>E Model:</p> 	 <p>Rectangular ASA enclosure with on/off switch</p>

INDUSTRIES



Water & Environment



Agriculture & Farming



Oil & Gas



Marine & Oceanography



Mining & Construction



Smart Building & HVAC

APPLICATIONS

- Water Tank Level Monitoring
- Diesel Tank Level Monitoring
- Flood Monitoring
- Open Channel Level Monitoring
- Corrosive Liquid Storage Level Monitoring
- Distance Measurement
- People Counting
- Long Range Object Detection

ORDERING CODE

DUS2-N						
Communication Type						
B: NB-IoT			C: Cat-M1			
Measurement Range						
5, 10 meters						
Enclosure						
C5: Cylindrical housing, IP65			E5: Rectangular housing, IP65			
Device Activation						
S: on/off switch			X: No switch (always on)			
Antenna						
I: Internal			E: External			
Options						
(On request) ¹						
DUS2-N	B	5m	C5	X	I	

Sample Product Code:

- **DUS2-N-B-5m-C5-X-I**

NB-IoT ultrasonic distance sensor, range of 5m, with C5 housing (compact and IP65 rated), always on and with internal antenna.

¹⁾ Product Options:

- **EP**: sensor with external power supply connector for 12V supply (only for E type enclosure, adaptor is not included)
- **EPB**: connector for 12V supply with internal battery backup (only for E type enclosure)
- **HG**: high-gain external antenna
- **WF**: Active WiFi module on device for communication/ firmware update through Mobile phone NFC module (only for E type enclosure)
- **HCB**: high-capacity battery (only for E type enclosure)