

*Autoclavable & UV resistant*

# OXFORD BenchMate L

Digital micro pipette for liquid handling

## User's Manual

CE

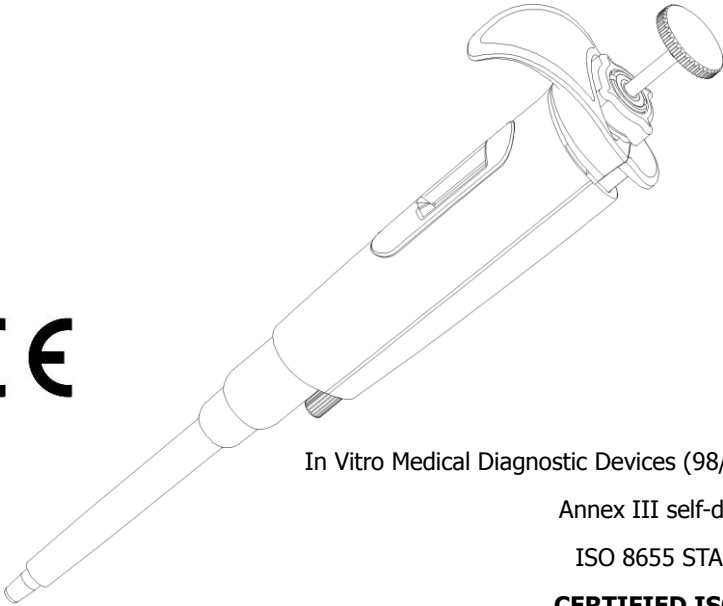

In Vitro Medical Diagnostic Devices (98/79/EC)

Annex III self-declared

ISO 8655 STANDARD

**CERTIFIED ISO9001**

- Thank you for purchasing Oxford BenchMate L pipettes
- Learn more about Oxford Lab Products at [www.oxfordlp.com](http://www.oxfordlp.com)
- Please read this manual carefully before using

**OXFORD**  
**LAB PRODUCTS**

*Autoclavable & UV resistant*

# **OXFORD** **BenchMate L**

**Digital micro pipette for liquid handling**

## **Features**

- Oxford BenchMate L is fully autoclavable at the condition of 121°C for 20 minutes.
- Oxford BenchMate L is made of UV resistant material which can be used in a clean room environment.  
(If UV is applied to the Oxford BenchMate L Pipettes for a considerably long time, it may become discolored but it will not impact performance.)
- A new round shape improves friendly handling capability, and mitigates the operator's fatigue from long time use.
- Sample volume can easily be set by simply rotating the push button.
- Setting of sample volume can easily be locked with one touch (one-touch lock mechanism).
- A wide range of sampling volume can be covered by six models from 0.1uL to 1000uL.
- A patented body construction avoids permeating hand temperature through the body that prevents inaccuracy of volume measurement.
- Since PTFE (Fluoroplastic) is used in an airtight chamber, this combination keeps airtight and precise reproducibility for long hours.
- A thin nozzle can be easily inserted and can reach the bottom of many tubes for dispensing/aspiration. (110mm in depth, 2uL – 1000uL)
- Tips can be removed without touching them by using the tip ejector.
- The Easy-Calibration function provides smooth and easy adjustment with an attached adjustment tool.

## **Standard Accessories**

- Three Tips
- Grease
- An Adjustment Tool
- User's Manual
- Warranty Card

When unpacking the box, check to make sure that the above-mentioned items are included.

## **Precautions on Safety**

- Please read the "CAUTION" section on the next page before starting to use Oxford BenchMate L pipettes
- Contents of "CAUTION" will provide you with information on how to properly handle pipettes to prevent accidents and physical damage.
- After reading this manual, please keep it in a convenient place nearby for reference.

**Please read the following prior to use for your safety and correct usage.**



**Be sure to observe the following instructions for using Oxford BenchMate Pipettes properly and safely.**

If user misuses "Oxford BenchMate L Pipettes", or disregards the following instructions, it may result in injury to the user or/and other persons or physical damage to the pipette or/and other equipment.

1. Do not use this pipette for any purpose except pipetting/dispensing liquid.
2. Do not modify the pipette, because modification may cause an accident.
3. Do not use the pipette for pipetting any liquid to be injected into human body.
4. Do not expel dispensed liquid towards anybody.
5. Do not eject tip towards anybody.
6. Do not eject tip with liquid inside.
7. Carefully handle the pipette and tip because the tip is sharply pointed.
8. If the pipette is contaminated with liquids harmful to a human, immediately take appropriate disposal steps to clean it safely before continuing to work.
9. Do not use the pipette for stirring liquid and so on, otherwise not only may the tip be loose and fall off but the pipette may be soiled with scattered liquid.
10. Do not touch filters which may be contaminated by harmful substances.
11. Be careful when removing Nozzle filters from the 5000ul and 10000ul pipettes as the Nozzle filter remover is sharp.
12. Do not touch autoclaved pipette directly right after drying. Touching hot pipettes directly after drying may cause injury.
13. Components of water used for autoclave may cause pipette malfunction or performance.
14. If the pipette cannot be fixed after examining immediately stop using the pipette and ask us or our agent to repair it.
15. For organic solvents, dense and volatile liquids, contact us for the best liquid handling solutions.
16. Although this pipette has good chemical-resistance in general, it may be damaged by certain corrosive chemicals. Please contact us when using strong corrosive chemicals.
17. The pipette can be used between +4°C and +40°C, but the specifications may vary.
18. Depending on frequency of use, the pipette should be cleaned in a soap solution and airtight chamber should be maintained according to this manual.

# Note

**Users are required to strictly observe the following in order for the pipette to keep its excellent precision, reproducibility and original performance.**

1. Do not expose the pipette directly to the sun 2 hours before starting work, otherwise the pipette may lose accuracy. Avoid working with pipettes in a humid and hot place.
2. Before starting to work with the pipette, avoid touching the tip and nozzle cylinder. If the nozzle cylinder is impacted by your hand, accuracy may vary.
3. For pipetting, follow the forward method (the way it is explained in this manual). If it is performed in a different way, it may result in inaccurate pipetting.
4. Operate the push button very gently. If it is quickly released, it may result in inaccurate pipetting and the liquid aerosols may travel into the pipette's body. To prevent the pipette from malfunction, inaccuracy and contamination, a filter is attached to models OB2-1000, -5000, and -10000. (A filter is supplied at time of purchase.) We also recommend using filter tips when performing any sensitive work and/or to avoid contamination. Contact us for the recommended tips for Oxford Pipettes.
5. Do not reuse tips that have been used once. Carefully dispose used tips. If a tip is used repeatedly, it may cause inaccurate and impure pipetting and cross contamination (\*) among samples.  
\* For example, if previous sample liquid is left inside the tip and it is mixed with a new sample liquid, the new sample is contaminated by the previous sample. Therefore, pipetting of the next sample may produce inaccurate results.
6. Do not hold the pipette horizontally or upside down when there is liquid inside the tip, otherwise the liquid will get into the main body and the pipette may be contaminated.
7. When autoclaving, do not pile pipettes on top of each other in the autoclave or lean pipettes with a nozzle top facing down. This pipette is made out of an autoclave compatible material, but because of the high temperature in the sterilizer, there is a risk that parts subject to load could be deformed.
8. After autoclaving and drying the pipette, leave it until it is completely cooled before using it again. If the pipette is used when warm, you will experience inaccuracy and imprecision.
9. After autoclaving and drying the pipette, assemble the pipette after it is completely cooled, if it is assembled when it is still hot, it may cause deterioration in the pipette such as breakage of the screw threads.
10. When rotating the push button, do not exceed the specified sample volume limit, otherwise the pipette may be damaged.
11. Do not perform pipetting with less liquid than set volume. If the quantity of liquid is less than the set volume, it may cause the liquid to scatter into the main body and the pipette may deteriorate in quality.

Contents

Operating Procedure ..... 5

Disassembling/Reassembling the Airtight Chamber ..... 9

Autoclaving/Drying the Pipette ..... 16

Specification ..... 17

Volume Setting Procedure ..... 18

Troubleshooting ..... 20

Parts List ..... 21

## Operating Procedure

### 1. Volume Setting

- 1) Turn the lock lever to unlocking direction to loosen it (Fig. A)
- 2) Turn the push button to set the digital counter to a desired liquid volume. To increase volume setting, turn the push button until passing designated volume setting by half of the scale, and then set the designated volume. To decrease volume setting, simply turn to designated volume. When setting the liquid volume, set the counter's graduation at point mark (red) appearing in the lower part of counter window. (Fig. B)
- 3) After setting the liquid volume, turn the lock handle toward the locking direction to lock it. (Fig. A)

**Note: Do not exceed the specified liquid volume limit, otherwise pipette may be damaged.**

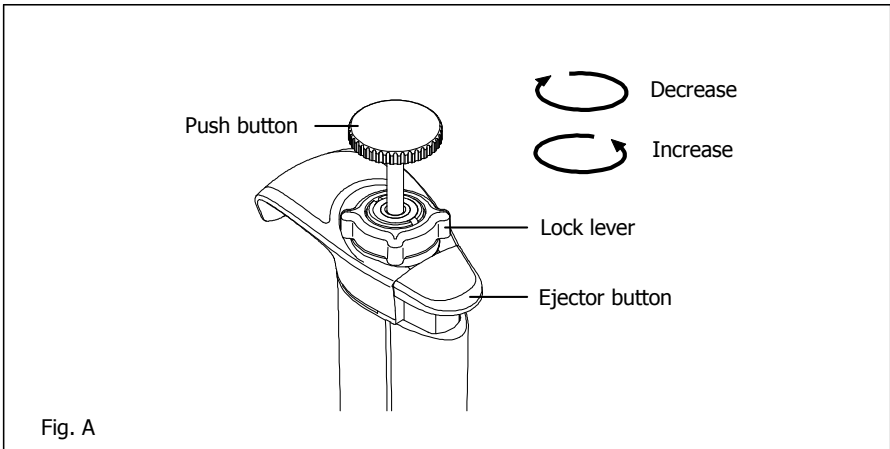

**Volume indicator**

NLF-2	NLF-10	NLF-20	NLF-100	NLF-200	NLF-1000	
□	<b>1</b>	□	<b>1</b>	□	<b>1</b>	
<b>2</b>	<b>0</b>	<b>2</b>	<b>0</b>	<b>2</b>	<b>0</b>	
0	0	0	0	0	0	
0	0	0	0	0	0	
▲	▲	▲	▲	▲	▲	Point mark
2 μL (0.002)	10 μL (0.01)	20 μL (0.02)	100 μL (0.1)	200 μL (0.2)	1000 μL (1)	Minimum scale: μL

Fig. B

## 2. Aspirating Liquid

- 1) Attach a new tip to the nozzle end. (We recommend that you attach it from the tip rack)

**Note: It is recommended that tips are directly mounted onto the pipette from the tip rack. Do not twist the pipette when mounting tips. Twisting the pipette may damage the tip cone and the internal components of the pipette.**

- 2) Press push button down to first stop position "b". (Fig. C)  
\* Don't aspirate the liquid with the push button pressed at the second stop "c".
- 3) Hold the pipette vertically and immerse the tip 2mm to 3mm below the surface of the liquid. (Fig. D-①)
- 4) Release the push button slowly and smoothly to aspirate the set volume of the liquid. (Fig. D-②)
- 5) Wait 1 to 2 seconds, then withdraw the pipette vertically and carefully from the surface of the liquid. (Fig. D-③)
- 6) Wipe any droplets away from the outside of the tip using a medical wipe and avoid touching the tip's orifice.

**Note: Do not aspirate when the push button position is at "c".**

**Note: The push button has to be pushed and released slowly. Otherwise it may cause inaccuracy.**

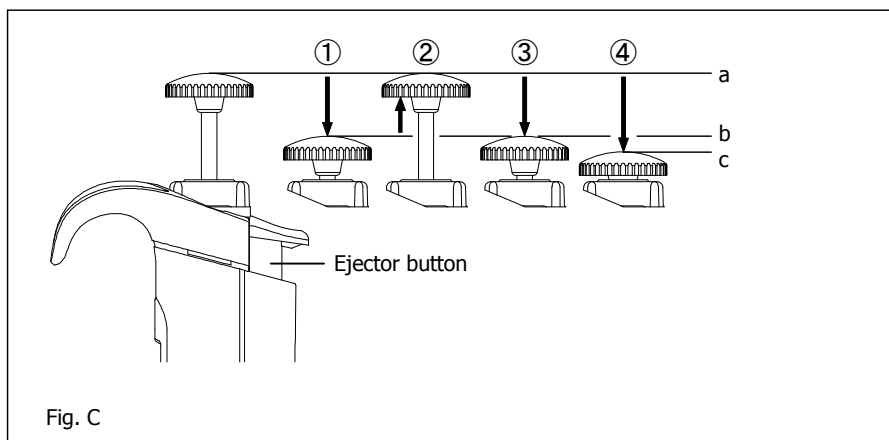

### 3. Dispensing Liquid

- 1) Gently place the end of the tip against the inside wall of the recipient vessel just above the liquid surface 10 degrees to 45 degrees in angle.
- 2) Press the push button down slowly and smoothly to the first stop "b". Wait for a few seconds, then press the push button down to the second stop to expel the last drop of the liquid from the tip. (Fig. D-④, ⑤)
- 3) Release the push button slowly.
- 4) Press the ejector button to remove the tip and dispose of it. (Fig. D-⑥)



**When using any toxic or harmful liquid to humans, do not touch any used tips.**

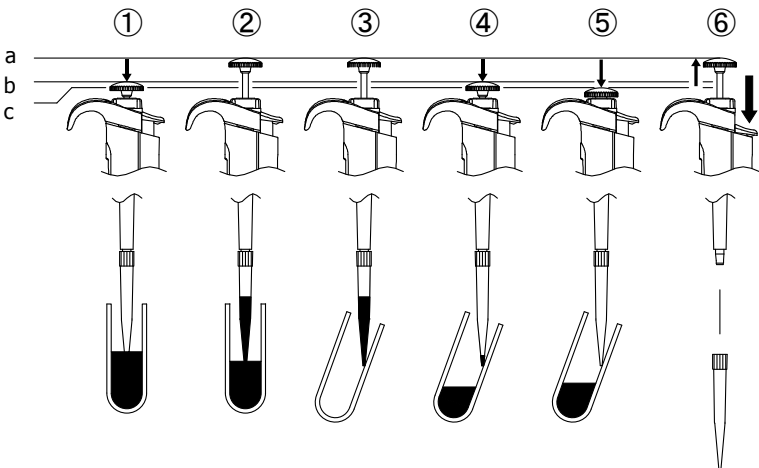

Fig. D



#### 4. Recommendations for Accurate Pipetting

In addition to the above mentioned operations of pipetting, the following procedure maximizes performance of the pipette.

- 1) Make sure that the tip is firmly attached to the nozzle end.
- 2) Before pipetting, pre-rinse the tip by filling and expelling the liquid from the tip three to five times. This will increase precision especially when pipetting viscous or vaporous liquids.

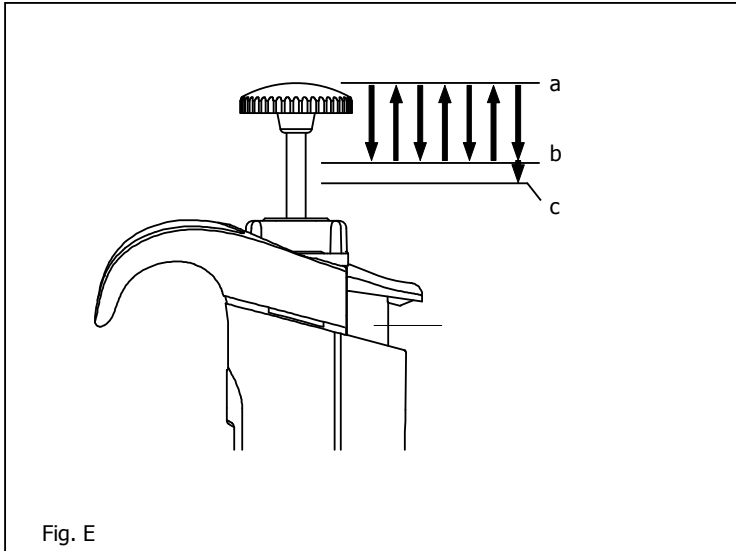

- 3) When pipetting volumes under 50ul, the operation should be done very slowly and smoothly. The air humidity should be as high as possible to reduce the effect of evaporation loss.
- 4) When aspirating high density liquids and viscous solutions, once the liquid has entered the tip, wait 2 to 3 seconds before removing the tip from the surface of the liquid. When dispensing, wait 2 to 3 seconds at the first stop position before pushing to the second stop position.

## Disassembling/Reassembling the Airtight Chamber

If such symptoms as mentioned in "Troubleshooting" (page 20) occur, disassemble and inspect pipette according to the following procedures.

### 1. Disassembling

- ① Remove an ejector setting screw. Fig. F-(1-1)

Turn the ejector setting screw towards the direction of the arrow to remove it, and then pull the ejector pipe out toward the direction of arrow.

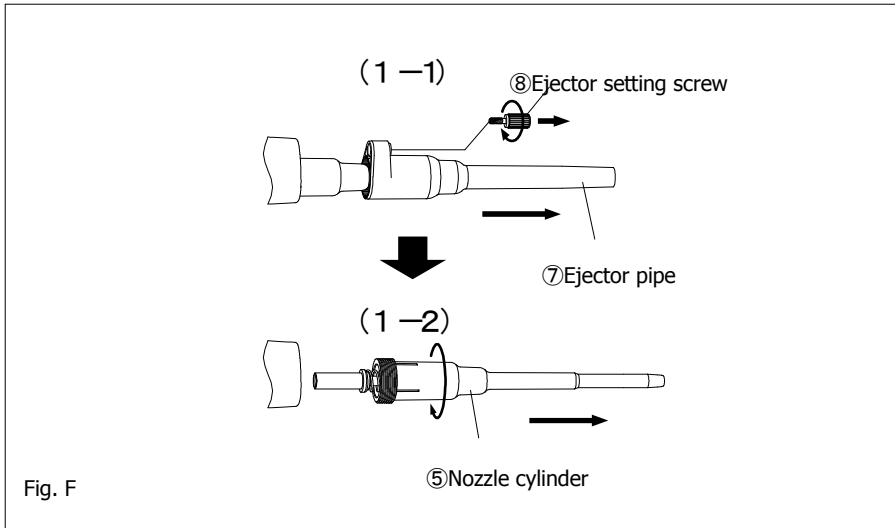

- ② Turn the nozzle cylinder counterclockwise to remove it, as it is screwed into the main body. Fig. F-(1-2)

**Note: When removing the nozzle cylinder, pay attention to the internal parts as some of them occasionally spring out of the body (for types of 2ul to 1000ul volume).**

- ③ Remove internal parts one after another. Fig.H1, H2, H3, H4

- 2, 10uL: Fig H1

Remove the plunger set, 1st spring, O-ring retainer. The O-ring and seal ring are fixed to the nozzle cylinder and cannot be removed.

- 20uL: Fig H2

Remove the plunger set, 1st spring, 1st spring holder, seal spring, O-ring retainer from the nozzle cylinder. The O-ring and seal ring are fixed to the nozzle cylinder and cannot be removed.

- 100uL, 200uL: Fig H3, 1000uL: Fig H4

Remove the plunger set, 1st spring, 1st spring holder, seal spring, O-ring retainer and O-ring from the nozzle cylinder.

**Note: Shapes of the O-ring retainer are different by size of pipette.**

**Note: Pay attention to small parts as you do not want to lose them during disassembly process.**

## 2. Reassembling

① Apply grease on plunger set and O-ring if necessary. Refer to Sec. 3 "Grease Up".

② Reassemble nozzle cylinder.

- 2, 10uL: Fig H1

Firstly, set 1st spring on plunger set, next set O-ring retainer, seal ring and O-ring in this order.

Then, insert assembled plunger into the nozzle cylinder and screw it into the body. The O-ring and seal ring are fixed to the nozzle cylinder for 2uL and 10uL model.

20uL: Fig H2

Firstly, set the 1st spring on plunger set, next set 1st spring holder, seal spring, O-ring retainer, seal ring and O-ring in this order. Then insert the assembled plunger into nozzle cylinder and screw it into the body. The O-ring and seal ring are fixed to the nozzle cylinder for 20uL model.

**Note: When reassembling, be careful not to put the seal ring and O-ring in the wrong order. If the order is wrong, it may cause not only leakage but also inaccuracy, failure in extracting liquid, etc.**

100, 200uL: Fig. H3, 1000uL: Fig. H4

First, set the 1st spring on plunger set, next 1st spring holder, seal spring, O-ring retainer, and O-ring in this order. Insert assembled plunger into the nozzle cylinder and screw it into the body.

**Note: When screwing into the body, make sure that the nozzle cylinder and the body are in vertical direction, and screw the nozzle cylinder into the body very gently. If not, it may cause leakage.**

③ Fit the ejector pipe to the body.

- 2, 10, 20uL: Fig H1, 100, 200uL: Fig. H3, 1000uL: Fig. H4

While pressing the ejector button down with your finger so that the metal stay sticks out from just under the grip, insert the ejector pipe into the body and fix it with the ejector setting screw. When ejection needs extra strength, snugly adjust position of the ejector pipe.

**Note: After reassembling, repeat trial operation several times and inspect that there is nothing wrong with the pipette.**

### 3. Grease up

- ① Remove the old grease from the plunger set and the O-ring.

For 2 $\mu$ L, 10 $\mu$ L and 20 $\mu$ L model, the O-ring is fixed in the nozzle cylinder and grease is to be applied only on the plunger set.

- ② Apply grease on the area of approximately 40mm from the top of the plunger set which is indicated in gray in the fig. G

**Note: Please make sure to use designated grease for Oxford BenchMate L. Warranty for the product may not be applied if the different grease is used.**

- ③ Apply a little amount of grease on the O-ring for 100 $\mu$ L, 200 $\mu$ L and 1000 $\mu$ L model.

**Note: It differs upon usage however; it is recommended to grease these parts at least every 6 months.**

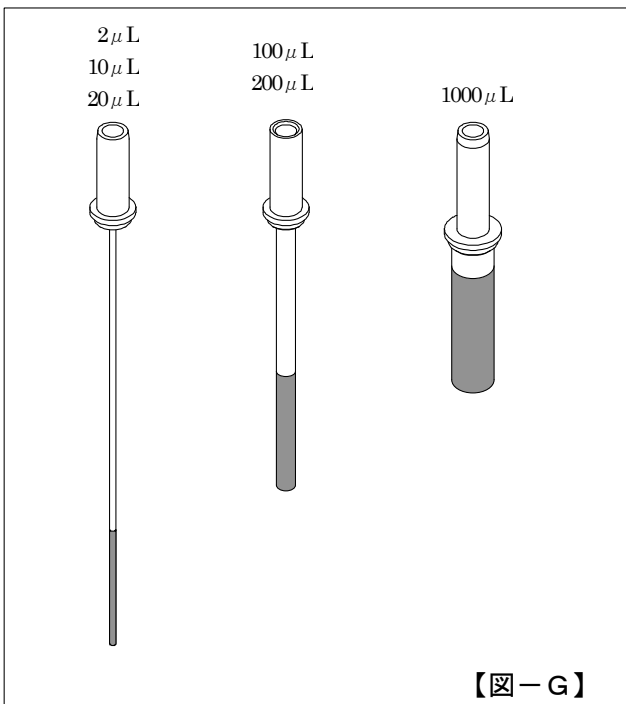

# OBL-2/OBL-10

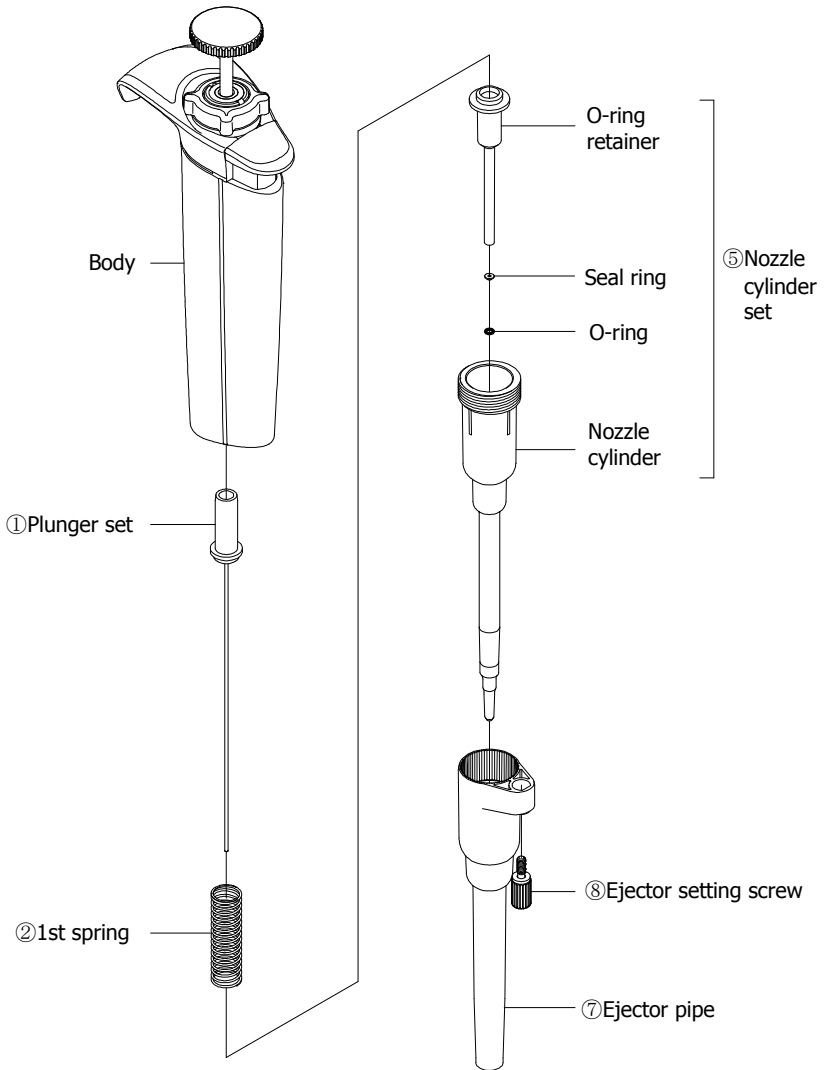
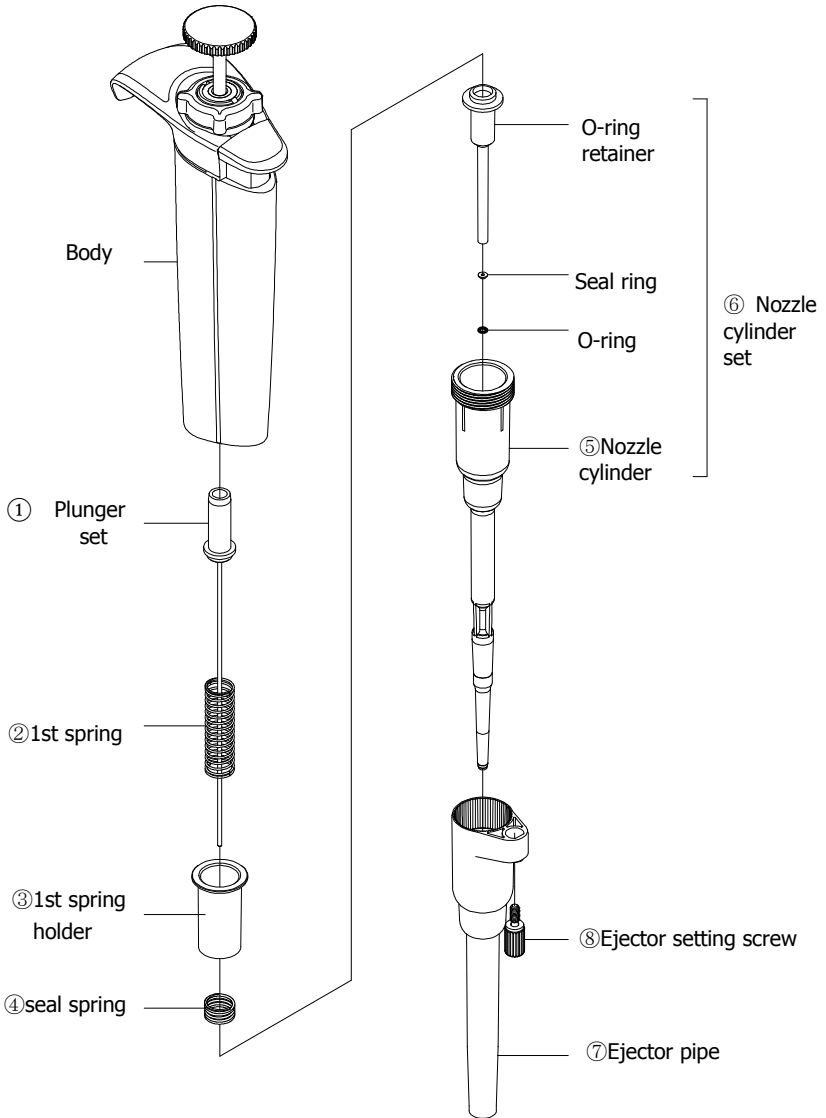

Fig. H1

# OBL-20



# OBL-100/OBL-200

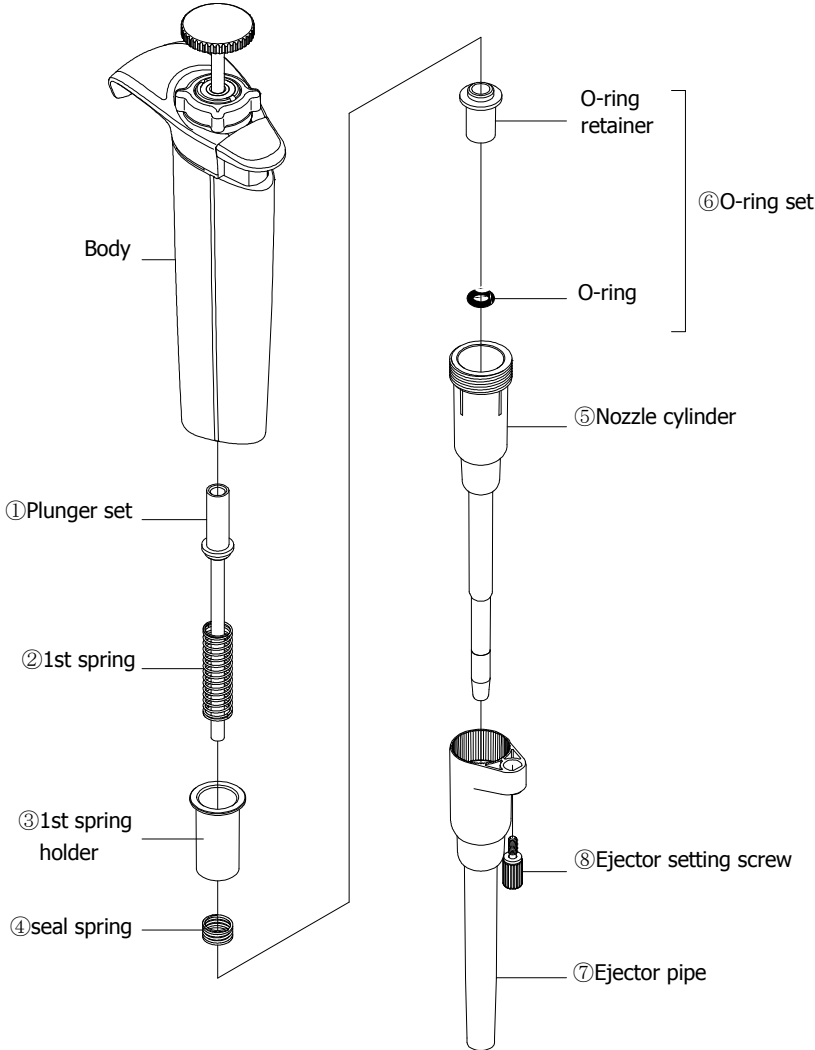

Fig. H3

# OBL-1000

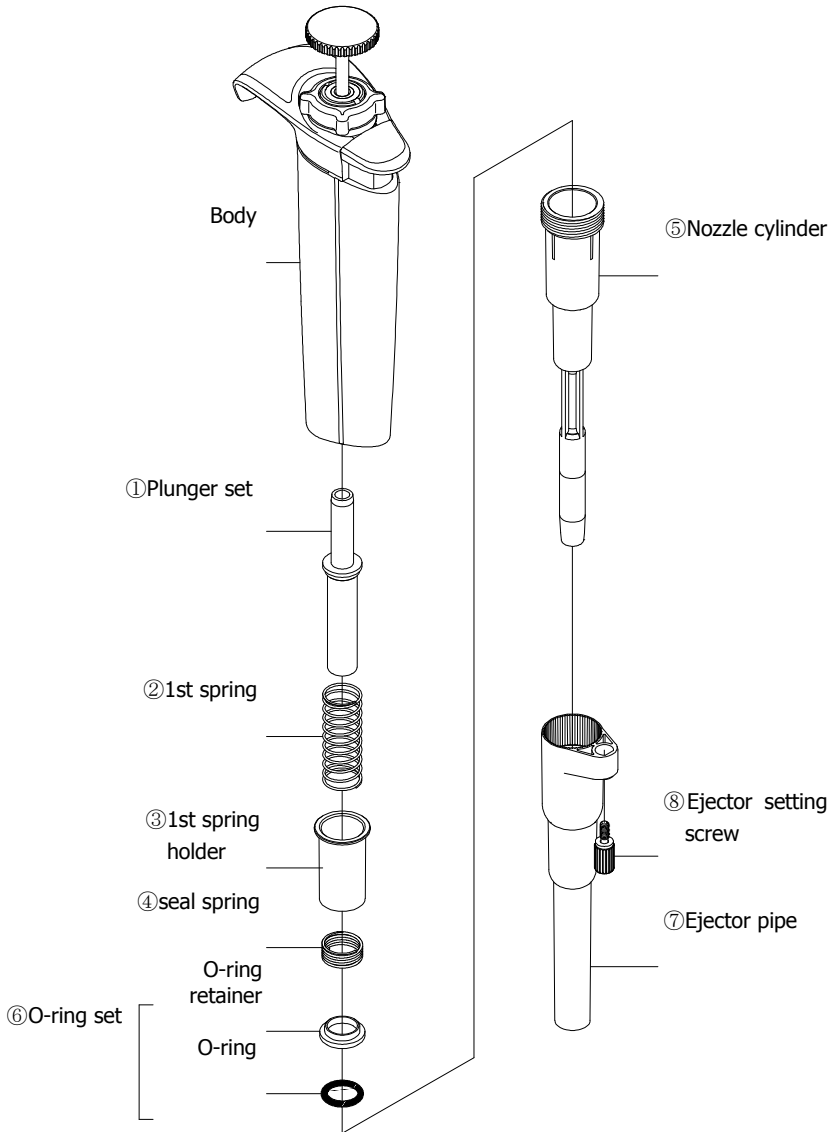

Fig. H4



## Autoclaving

This pipette is autoclavable. When autoclaving, set the autoclave at 121°C for 20 minutes following the procedure mentioned below.

- ① Release the lock lever from the locked position and set the counter graduation to the allowable limit of the liquid volume.
- ② After autoclaving is complete, dry the pipette completely.

**Note: When autoclaving, do not pile pipettes on top of each other in the autoclave or lean pipettes with a nozzle top facing down. This pipette is made out of an autoclave compatible material, but because of the high temperature in the sterilizer, there is a risk that parts subject to load could be deformed.**

## Drying the Pipette

Dry the pipette immediately after autoclaving is complete. It is necessary to dry the pipette with a constant temperature air-drier at 60°C for 60 minutes or longer.

- ① Pull out the ejector pipe, referring to “Disassembling” on page 9.
- ② Turn the nozzle cylinder counterclockwise by two and a half turns to loosen it.
- ③ Put the pipette in a constant temperatures air-drier for drying.
- ④ After the pipette is dry, wait until it returns room temperature and then fasten the nozzle cylinder and reassemble the ejector pipe into the body.

**Note: If the pipette is reassembled when it is still warm, it may cause breakdown or deterioration of the pipette such as breakage of the screw threads, etc. Be sure to reassemble the pipette after it has completely cooled down. If the pipette is used when it is warm, accurate liquid handling cannot be carried out.**



**: Don't touch the pipette directly right after drying, because it will be very hot. Touching the hot pipette directly may cause injury. Components of water used for autoclave may cause pipette malfunction or performance.**

## Specifications

Oxford BenchMate is a high quality pipette. The technical figures given in the Table-1 "Oxford BenchMate Maximum Permissible Errors" were obtained using genuine Oxford tips. Oxford Lab Products declares that Oxford pipettes comply with the requirement of the ISO 8655 Standard, by type testing. The adjustment is carried out under strictly defined and monitored conditions (ISO 8655-6):

- The basis of adjustment, OB
- Reference temperature, 20°C-25°C
- Relative humidity, more than 50%
- Barometric pressure, 101KPa,
- Use of distilled water, distilled water
- Ten measurements for each test volume at three points, nominal volume, 50% of nominal volume and the minimum or 10% of nominal volume.

Table-1: Oxford BenchMate L Maximum Permissible Errors

Pipette types (Code)	Volume range	Volume (uL)	Accuracy (systematic error) AC (%)	Precision (random error) CV (%)
OBL-2	0.1-2 (uL)	0.2	±12.0*	≤6.0*
		1	±5.0	≤2.5
		2	±3.0	≤1.0
OBL-10	0.5-10 (uL)	1	±4.0	≤3.0
		5	±1.0	≤1.0
		10	±1.0	≤0.5
OBL-20	2-20 (uL)	2	±5.0	≤3.0
		10	±1.0	≤1.0
		20	±1.0	≤0.4
OBL-100	10-100 (uL)	10	±2.0	≤1.0
		50	±1.0	≤0.3
		100	±0.8	≤0.3
OBL-200	20-200 (uL)	20	±1.0	≤0.5
		100	±0.8	≤0.3
		200	±0.8	≤0.2
OBL-1000	100-1000 (uL)	100	±1.0	≤0.5
		500	±0.8	≤0.3
		1000	±0.7	≤0.2

\*Obtained values for accuracy and precision may vary by familiarity of user especially less than 0.2uL with OBL-2

\* The data given in the table conform to the ISO 8655-6 standard.

## Volume Setting Procedure

\* For good volume setting (calibration), volume adjustment should be conducted minimum volume setting first and then followed by maximum volume setting for each size of pipettes.

- ① Loosen the lock lever freely.
- ② Insert the adjustment tool's tabs into the two grooves on the adjustment head. (Fig. L①)
- ③ Hold the unit in one hand and secure the adjustment tool not to turn. (Fig. L②)
- ④ Rotate the push button clockwise for dispensing volume increase (the counter display turns to lower), and counter-clockwise for dispensing volume decrease (the counter display turns to raise).
- ⑤ Please refer to the "Table-Calibration Guideline" below for approximate rotating scale on the display.

**Note: Be sure the lock lever is loosened before adjusting.**

**Note: Rotating directions for volume adjustment are as follows.**

**Dispensing volume increase (counter display turns to lower): clockwise**

**Dispensing volume decrease (counter display turns to raise): counter-clockwise**

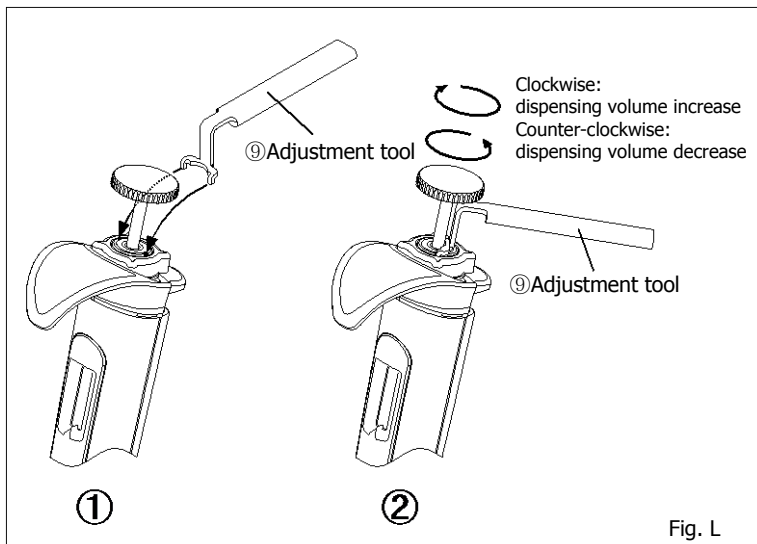

Table-2 Calibration Guideline

(Unit:  $\mu\text{L}$ )

	1 scale mark	2 scale marks	5 scale marks	10 scale marks
OBL-2	0.0015	0.0029	0.0073	0.0145
OBL-10	0.0077	0.0154	0.0385	0.0769
OBL-20	0.012	0.025	0.062	0.125
OBL-100	0.078	0.156	0.390	0.780
OBL-200	0.13	0.25	0.63	1.26
OBL-1000	0.79	1.58	3.96	7.91

The numerical values (volume) above are for reference only. For actual measurement, please use a balance which is properly calibrated.

## Volume Measurement

### Procedure

- ① In order to avoid influence from temperature, prepare pipettes for inspection, distilled water, balances and tips 2 to 3 hours before using where measurement is conducted.
- \* Measurement room should be controlled temperature between 20-25°C, and measurement should be held where there is no direct wind from air-conditioner.
- ② Pick up a proper tip from tip rack, and aspirate sample water.
- ③ Dispense the sample for measuring with a balance.
- ④ Read volume measurement by the balance, and compute accurate volume by following the formula.

$$V_i = m_i \times Z$$

$V_i$  : Volume  
 $m_i$  : Measured volume  
 $Z$  : Z correction factor

- ⑤ Add all 10-time  $V_i$  volumes, and divide the sum by 10 to compute a mean volume.

$$\bar{V} = \frac{1}{10} \times \sum_{i=1}^n V_i$$

- ⑥ Calculate the systematic error  $e_s$  of the pipette, where  $V_s$  is the selected test volume.

$$e_s = 100 \times \frac{(\bar{V} - V_s)}{V_s}$$

- ⑦ Calculate the coefficient of variation, CV, by formula for standard deviation.

$$CV = \frac{100}{\bar{V}} \times \sqrt{\frac{\sum_{i=1}^n (V_i - \bar{V})^2}{n - 1}}$$

Table-3 Z correction factor for distilled water

Temperature (°C)	Air Pressure (kPa)			
	95	100	101.3	105
20.0	1.0028	1.0028	1.0029	1.0029
20.5	1.0029	1.0029	1.0030	1.0030
21.0	1.0030	1.0031	1.0031	1.0031
21.5	1.0031	1.0032	1.0032	1.0032
22.0	1.0032	1.0033	1.0033	1.0033
22.5	1.0033	1.0034	1.0034	1.0034
23.0	1.0034	1.0035	1.0035	1.0036
23.5	1.0036	1.0036	1.0036	1.0037
24.0	1.0037	1.0037	1.0038	1.0038
24.5	1.0038	1.0039	1.0039	1.0039
25.0	1.0039	1.0040	1.0040	1.0040

## Troubleshooting

Symptom	Possible cause	Remedy
Tip cannot be ejected.	Nozzle cylinder loosens	Tighten up the nozzle cylinder securely.
Pipette fails to aspirate liquid.	Top of the nozzle cylinder is clogged with a foreign object.	Clean up the nozzle cylinder or replace it with a new one.
	Nozzle cylinder loosens.	Tighten up the nozzle cylinder securely.
	Seal ring set are assembled in reverse order. (2, 10, 20uL models only)	Reset the seal ring and O-ring set according to the manual in "Disassembling/Reassembling".
	Seal ring or/and O-ring set are worn (2, 10, 20uL models only).	Replace O-ring set. For 2uL 10uL, 20uL model, replace nozzle cylinder set.
	Grease on plunger set or/and O-ring is gone.	Apply grease by following the instruction on this manual.
Extracted liquid leaks from tip.	Seal ring or/and O-ring set are worn (2, 10, 20uL models only).	Replace O-ring set. For 2uL 10uL, 20uL model, replace nozzle cylinder set.
	Nozzle cylinder loosens.	Tighten up the nozzle cylinder securely.
	Nozzle cylinder is worn (stepped wear can be checked by eye).	Replace nozzle cylinder.
	The O-ring and/or seal ring is worn because the plunger set is damaged or rusted.	Replace Plunger set and O-ring set. For 2uL 10uL, 20uL model, replace Plunger set and Nozzle cylinder set.
	The tip is loosely attached.	Firmly attach the tip to the nozzle.
	Grease on plunger set or/and O-ring is gone.	Apply grease by following the instruction on this manual.
Push button moves stiffly.	A liquid is gone into the nozzle cylinder.	Clean up the nozzle cylinder, plunger set and O-ring first. Replace these parts if the situation is not improved.
	Grease on plunger set or/and O-ring is gone.	Apply grease by following the instruction on this manual.



CAUTION

**If the pipette cannot be fixed after examining and conducting the above mentioned procedures, immediately stop using the pipette and ask us or our agent to repair it.**

**Before bringing the pipette for repair, be sure to check whether it has been contaminated with microbes or harmful substances.**

## Consumables

Oxford Lab Products offer a wide range of pipettes, tips, plastic consumables, and benchtop equipment. View our complete product offering at [www.oxfordlp.com](http://www.oxfordlp.com)

### Spare Part list

	Code	Description	Content	Type in volume
①	00-OBL-0100002	Plunger set 2uL	Plunger head/plunger	2uL
	00-OBL-0100010	Plunger set 10uL	Plunger head/plunger	10uL
	00-OBL-0100020	Plunger set 20uL	Plunger head/plunger	20uL
	00-OBL-0100100	Plunger set 100uL	Plunger head/plunger	100uL
	00-OBL-0100200	Plunger set 200uL	Plunger head/plunger	200uL
	00-OBL-0101000	Plunger set 1000uL	Plunger head/plunger	1000uL
②	00-OBL-0200002	First spring 2uL	-----	2uL
②	00-OBL-0200010	First spring 10uL	-----	10uL
②	00-OBL-0200020	First spring 20uL	-----	20uL
②	00-OBL-0200100	First spring 100uL	-----	100uL
②	00-OBL-0200200	First spring 200uL	-----	200uL
②	00-OBL-0201000	First spring 1000uL	-----	1000uL

	Code	Description	Content	Type in volume
③	00-OBL-2300020	1st spring holder 20uL	-----	20uL
③	00-OBL-2300100	1st spring holder100uL	-----	100uL
③	00-OBL-2300200	1st spring holder 200uL	-----	200uL
③	00-OBL-2301000	1st springholder1000uL	-----	1000uL
④	00-OBL-2200020	Seal spring 20uL	-----	20uL
④	00-OBL-2200100	Seal spring 100uL	-----	100uL
④	00-OBL-2200200	Seal spring 200uL	-----	200uL
④	00-OBL-2201000	Seal spring 1000uL	-----	1000uL
⑤	00-OBL-0400002	Nozzle cylinder set 2uL	O-ring/seal ring/O-ring retainer/nozzle cylinder	2uL
⑤	00-OBL-0400010	Nozzle cylinder set 10uL	O-ring/seal ring/O-ring retainer/nozzle cylinder	10uL
⑤	00-OBL-0400020	Nozzle cylinder set 20uL	O-ring/seal ring/O-ring retainer/nozzle cylinder	20uL
⑤	00-OBL-0400100	Nozzle cylinder 100uL	-----	100uL
⑤	00-OBL-0400200	Nozzle cylinder 200uL	-----	200uL
⑤	00-OBL-0401000	Nozzle cylinder 1000uL	-----	1000uL
⑥	00-OBL-0500100	O-ring set 100uL	O-ring/O-ring retainer	100uL
⑥	00-OBL-0500200	O-ring set 200uL	O-ring/O-ring retainer	200uL
⑥	00-OBL-0501000	O-ring set 1000uL	O-ring/O-ring retainer	1000uL
⑦	00-OBL-0900010	Ejector pipe A	-----	2/10uL
⑦	00-OBL-0900200	Ejector pipe B	-----	20/100/200uL
⑦	00-OBL-09001000	Ejector pipe C	-----	1000uL
⑧	00-OBL-0801000	Ejector setting screw set	Setting screw/spring washer/washer	2/10/20/100/ 200/1000uL
⑨	00-OBL-1600000	Volume adjustment tool	-----	All
⑩	00-OBL-3400000	Grease	-----	All

For repair, service or information you may contact your local distributor.



Manufacturer:

**OXFORD**  
**LAB PRODUCTS**

Oxford Lab Products offer a wide range of pipettes, tips, plastic consumables and benchtop equipment. View our complete product offering at [www.oxfordlp.com](http://www.oxfordlp.com)

10360 Sorrento Valley Road, San Diego, CA 92121.

Tel – 1-800-243-3232

Fax – 858-536-3342

2016.Ver.1