

# AIR-MET SCIENTIFIC

## **AirMetER-AX**

# **MULTIPARAMETER AIR QUALITY MONITORING STATION**

User Manual



Before operating the unit, please read this user manual thoroughly and retain for future reference

Revision | MARCH 2024

# CONTENTS

Contents .....	2
Copyright Notice.....	3
Warnings, Cautionary Statements & Important Information .....	3
Warranty & Service .....	4
1. Overview.....	5
2. Monitor Assembly .....	6
AirMetER-AXII Layout.....	6
AirMetER-AXIV Layout.....	7
3. Detector Labeling .....	8
4. Installation.....	9
Conditions of Use .....	9
Location and Mounting of Monitor.....	10
5. Air-Met Scientific Data Portal .....	11
6. Maintenance.....	12
Maintenance Frequency .....	12
Troubleshooting .....	12
Filter Exchange .....	14
TSP Head Cleaning.....	15
Flow Rate Calibration .....	15
Module & Part Removal & Replacement .....	16
Heated Inlet Removal & Replacement .....	18
Gas Module Check.....	19
Calibration Gas Recommendation Table.....	19
Frequency Tables .....	20
Annual Calibration.....	21
7. Field Particulate Matter K Factor Adjustment .....	22
8. Spare Parts & Accessories .....	23
9. Specifications.....	24
Contact Information .....	26

# COPYRIGHT NOTICE

---

These help materials or any part thereof may not, without the written consent of Air-Met Scientific, be copied, reprinted, or reproduced in any material form including but not limited to photocopying, transcribing, transmitting, or storing it in any medium or translating it into any language, in any form or by any means, be it digitally, electronic, mechanical, xerographic, optical, magnetic, or otherwise.

The information contained in this document is proprietary and confidential and all copyright, trademarks, trade names, patents, and other intellectual property rights in the documentation are the exclusive property of Air-Met Scientific unless otherwise specified. The information (including but not limited to data, drawings, specification, documentation, software listings, source or object code) shall not at any time be disclosed directly or indirectly to any third party without prior written consent.

The information contained herein is believed to be accurate and reliable. Air-Met Scientific accepts no responsibility for its use by any means or in any way whatsoever. Air-Met Scientific shall not be liable for any expenses, costs by damage that may result from the use of the information contained within this document. Although every effort is made to ensure accuracy, the specifications of this product and the content herein are subject to change without notice.

# WARNINGS, CAUTIONARY STATEMENTS & IMPORTANT INFORMATION

---

Throughout this manual any warnings, cautionary statements or notes of importance are identified using the following symbols:

	<b>IMPORTANT INFORMATION</b>
---	------------------------------

# WARRANTY & SERVICE

---

Air-Met Scientific maintains instrument service facilities nationwide. Should your instrument require service, you may contact us on **1800 000 744** or at [service@airmet.com.au](mailto:service@airmet.com.au). Alternatively, instrument service may be booked by completing our online service request form at the following URL:

<https://www.airmet.com.au/services/book-a-service>

For non-warranty repairs, you will need to provide a purchase order number. All instruments submitted for repair will undergo evaluation by a service technician and a quote for works required will be issued, for approval, before any service proceeds.

Please note that, if a service quote is declined, a small charge for instrument assessment may apply.

Air-Met Scientific's policy is to perform all repairs required to restore the instrument to full operating condition, including replacement of sensors and batteries (as applicable) that have exceeded the recommended service life and the completion of any manufacturer issued service dispositions.

The unit for repair may be sent to your local Air-Met Scientific branch office. Pack the instrument and all its accessories (preferably in its original packing). Include any special instructions, your contact and company details and a description of the fault. Repairs are warranted for 90 days from the date of shipment. Sensors and other consumables have individual warranties.

	<p><b>Air-Met Scientific assumes no liability for work performed by unauthorised service facilities.</b></p>
---	--

The product specified in this manual is warranted against faulty workmanship for a period of 12 months, from the date of dispatch.

Our obligation assumed under this warranty is limited to the replacement of parts which, by our assessment, are proved to be defective and have not been misused, carelessly handled, defaced or damaged due to incorrect installation or operation. This warranty is VOID where the unit has been tampered with or if repairs have been made or attempted by anyone except an authorised representative of the manufacturing company.

Products for attention under the terms of this warranty (unless otherwise agreed) must be returned to the manufacturer, freight paid and, if accepted for free repair, will be returned to the customers address in Australia free of charge.

When returning the product for service or repair a full description of the fault and the conditions of operation when the product failed must be given. In any event the manufacturer has no other obligation or liability beyond replacement or repair of this product. Modifications may be made, by the manufacturer, to any existing or future models of the unit as it may deem necessary without incurring any obligation to incorporate such modifications in units previously sold or to which this warranty may relate.

# 1. OVERVIEW

---

The AirMetER-AX is a compact, and easy to install air quality monitoring station. The modular design allows the unit to support 1-8 gas sensors, PM<sub>2.5</sub> and PM<sub>10</sub> as standard with PM<sub>1</sub>, PM<sub>4.25</sub> and TSP optional, general weather conditions and noise measurements.

Designed to withstand various weather conditions, the AirMetER-AX is housed in a weather resistant enclosure ideal for round the clock continuous outdoor monitoring. The AirMetER-AX has datalogging capacity at a minimum of 365 days at one-minute intervals with built-in log and forward capability to locally store the data in the event of a network disruption.

Integrating seamlessly with Air-Met Scientific's web-based portal for remote data access, this secure data portal enables users to access monitoring logs, set customisable alerts, manage monitoring reports and more. The web-service application is accessible on both desktop PC and mobile smart devices.

The AirMetER-AX should be powered on 12VDC and is available with an optional Bluetooth enabled solar-power system that can provide up to 3 days autonomous operation.

For mains powered applications, an IP67 rated, 240VAC to 12VDC, 5A power supply is available.



**AirMetER-AX | Proudly Australian Made**

# 2. MONITOR ASSEMBLY

## AIRMETER-AXII LAYOUT

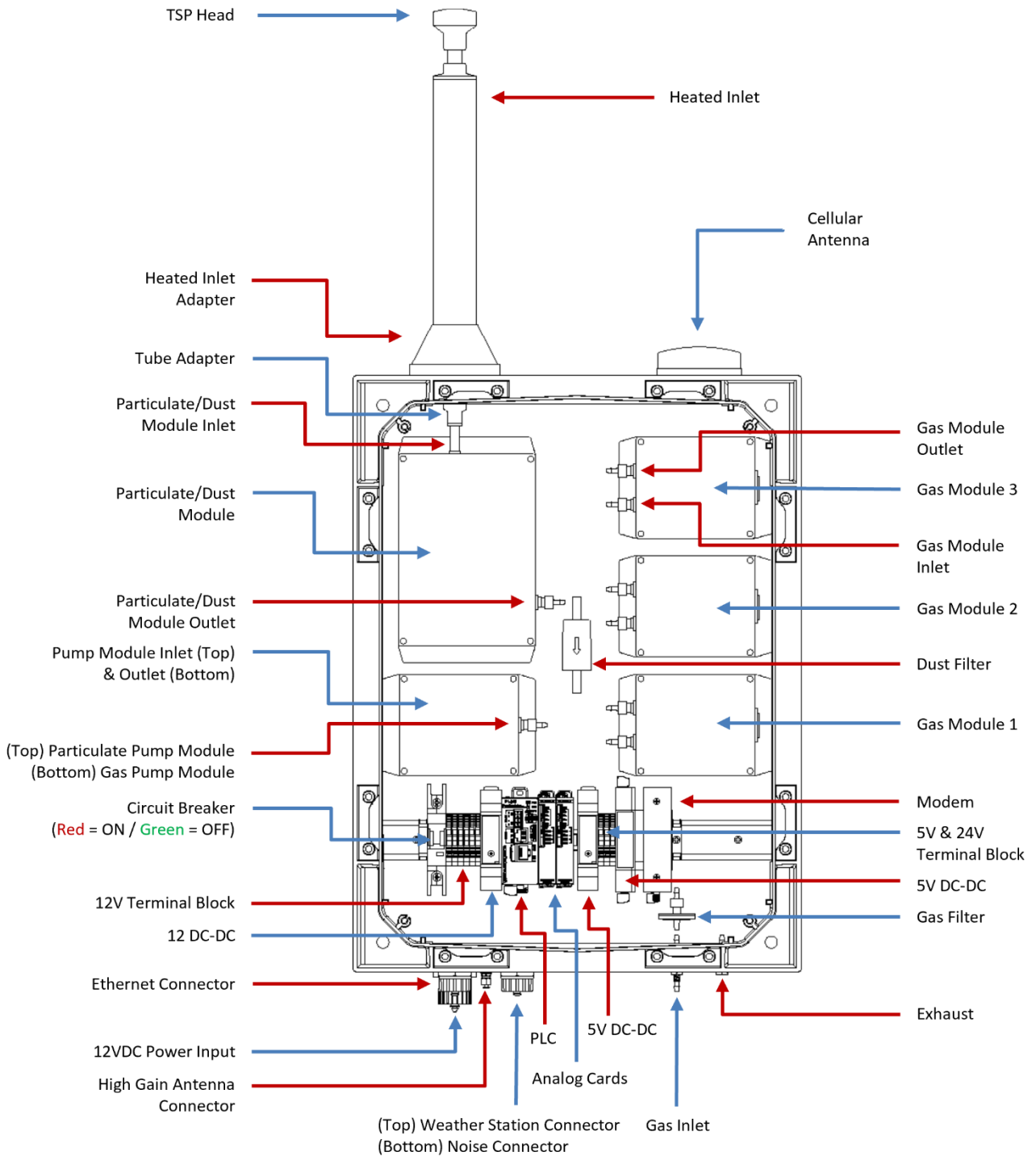

*Parts may vary according to configuration*

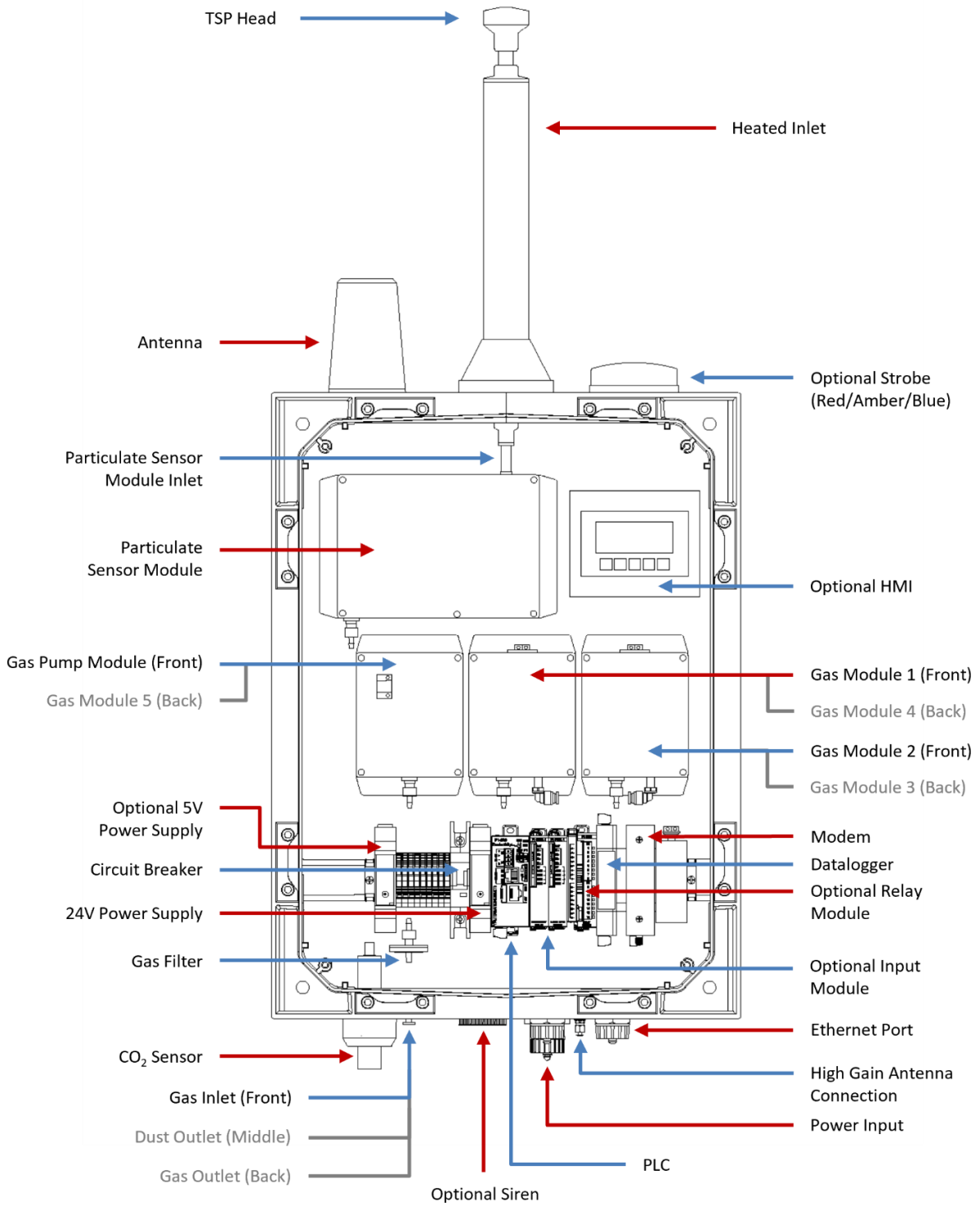

Parts may vary according to configuration

### 3. DETECTOR LABELING

---

Each detector is identified with the use of two labels. The labels contain the part and serial number information (Figure 3-1).

The labels are located on the inside surface of the instrument door.

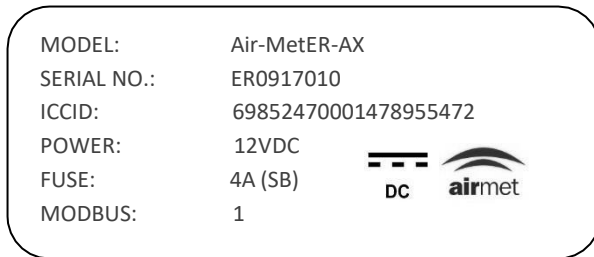
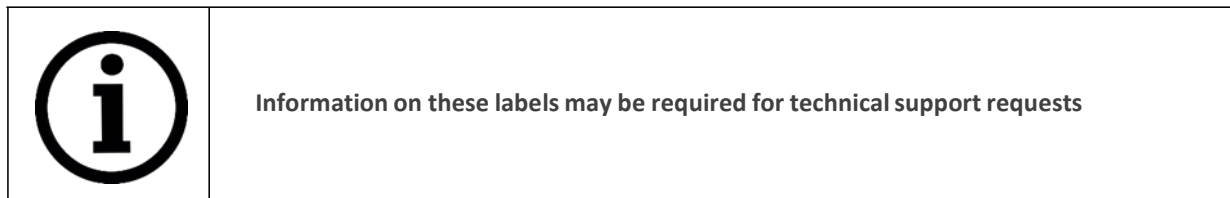

Figure 3-1 - Monitor Label Example





## 4. INSTALLATION

---



Use of the AirMetER-AX monitor in applications contrary to the conditions of use criteria may present a safety risk and/or void any instrument warranty.

### CONDITIONS OF USE

---

The AirMetER-AX is **NOT** certified for use in hazardous area classified zones.

The AirMetER-AX is supplied with brackets pre-fitted to support standard pipe-clamp pole mount inserts suitable for installation on standard masts or poles ranging from 40-105mm in diameter. An adjustable spanner or flat-blade screwdriver may be utilised to either tighten or release the pipe clamp to suit the intended structure diameter. Care should be taken during installation to ensure the AirMetER-AX is level and firmly secured.



Figure 4-1 - Mounting Brackets



Figure 4-2 - Pre-Fitted Brackets

## LOCATION AND MOUNTING OF MONITOR

Air-Met Scientific recommends the monitor is pole or tripod mounted in an open area free from buildings and other obstructions that may have an influence on measurements.

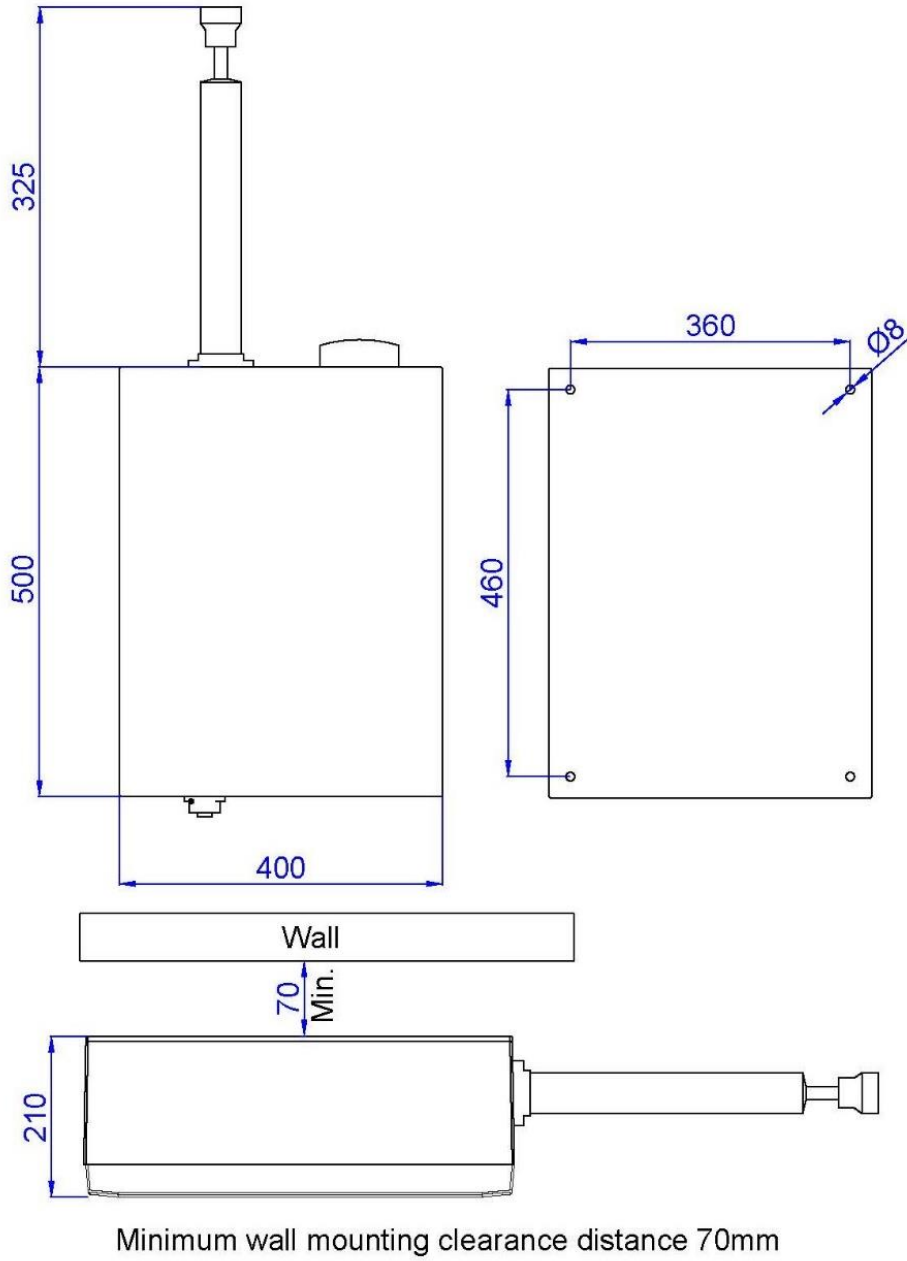

Figure 4-3 - External and Mounting-Point Dimensions (mm)

## 5. AIR-MET SCIENTIFIC DATA PORTAL

---

To access Air-Met's 'LiveSense' cloud platform, enter [airmet.livesense.com.au/login](http://airmet.livesense.com.au/login) into your browser and sign in using the credentials provided to you by your administrator.

The username must be your e-mail account – If you cannot remember your password, you may utilise the 'forgot password' function to reset this.

### Sign into your account

**LOGIN**  
User Name  
**THIS FIELD IS REQUIRED.**

**PASSWORD**  
Credentials  
**THIS FIELD IS REQUIRED.**

**Authenticate** [Forgot password?](#)

By default, this station will be setup with an activity alarm 'Comms Alarm' and basic graphical widgets on your dashboard.

Should you wish to modify your platform, please refer to Air-Met's 'LiveSense User Guide' for a complete overview of basic and more advanced functions available.

For further assistance or troubleshooting, contact [engineeredolutions@airmet.com.au](mailto:engineeredolutions@airmet.com.au)

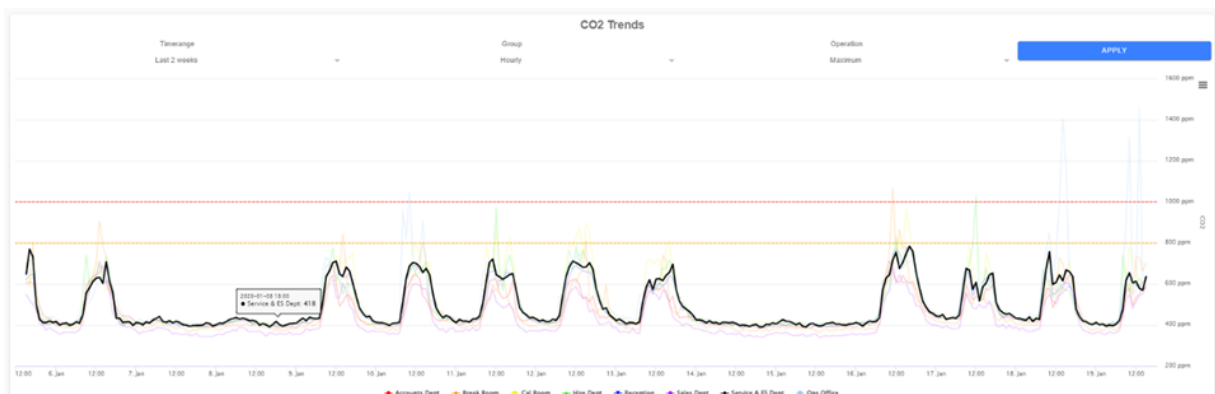

# 6. MAINTENANCE

---

## MAINTENANCE FREQUENCY

---

Air-Met Scientific recommends a maximum maintenance interval of 6 months. Service should include full zero and span calibration, assessment of filters for serviceability and functional test of all applicable alarms and outputs.

	<p><b>Specified maintenance and calibration intervals are recommendations only. A maintenance plan suitable for the application should be discussed internally. Alternatively, Air-Met Scientific can assist with this through a service agreement.</b></p>
---	---

	<p><b>Only trained technicians should attempt any disassembly or repairs on the AirMetER-AX.</b></p>
---	--

## TROUBLESHOOTING

---

ISSUE	SOLUTIONS
<p>I. No air flow at the exhaust</p>	<ol style="list-style-type: none"> <li>1. Are the pump modules plugged in at the top as displayed in Figure 6-8?</li> <li>2. Are the filters blocked and need replacement?</li> <li>3. Trace the tubing from the outlet of the top particulate pump module down to the external exhaust.</li> <li>4. Trace the tubing from the bottom gas pump module outlet through each of the installed gas sensor modules and out to the external exhaust for any signs of leaks or blockages.</li> <li>5. Follow the <a href="#">Flow Rate Calibration</a> section (page 15) to adjust the flow rate.</li> </ol>

<p>II. Air flow at the heated inlet not within the appropriate range. AXII 2L/m <math>\pm</math>5% AXIV 1L/m <math>\pm</math>5%</p>	<ol style="list-style-type: none"> <li>1. Are the filters blocked and in need of replacement?</li> <li>2. Is the top particulate pump module plugged in at the top as displayed in Figure 6-8?</li> <li>3. Are the heated inlet and particulate sensor modules connected by the tube adapter?</li> <li>4. Trace the tubing from the heated inlet &gt; particulate sensor module &gt; dust filter &gt; top particulate pump module &gt; exhaust t-piece &gt; external exhaust for any signs of leaks or blockages.</li> <li>5. Follow the <a href="#">Flow Rate Calibration</a> section (page 15) to adjust the flow rate.</li> </ol>
<p>III. Air flow at the outlet of the last gas sensor is not within the 0.85L/m <math>\pm</math>5%</p>	<ol style="list-style-type: none"> <li>1. Are the filters blocked and need replacement?</li> <li>2. Is the bottom pump module plugged in at the top as displayed in Figure 6-8?</li> <li>3. Trace the tubing from the gas inlet &gt; water stop filter &gt; bottom gas pump module &gt; all of the installed sensor modules &gt; exhaust t-piece &gt; external exhaust for any signs of leaks or blockages.</li> <li>4. Follow <a href="#">Flow Rate Calibration</a> section (page 15) to adjust the flow rate.</li> </ol>
<p>IV. Readings are low</p>	<ol style="list-style-type: none"> <li>1. Are the pump modules plugged in at the top as displayed in Figure 6-8?</li> <li>2. Check to make sure there is flow at the external exhaust.</li> <li>3. Check that the flow rates at the gas and heated inlets are as detailed from II. and III.</li> <li>4. Is the instrument due for calibration?</li> <li>5. Are the filters polluted and need replacement?</li> </ol>
<p>V. Either pump module not running</p>	<ol style="list-style-type: none"> <li>1. Is the pump module plugged in at the top as displayed in Figure 6-8?</li> <li>2. Is the modem on? If both the modem and pumps are not on, then the unit may not be powered on.</li> <li>3. Check the fuse and power supply.</li> </ol>
<p>VI. Data not uploading to LiveSense</p>	<ol style="list-style-type: none"> <li>1. Is the modem plugged in?</li> <li>2. Check the fuse and power supply.</li> </ol>
<p>VII. Instrument not turning on</p>	<ol style="list-style-type: none"> <li>1. Check the fuse and power supply.</li> </ol>

## FILTER EXCHANGE

The AirMetER-AX can contain up to three filters:

- > 9933-05-CQ - Dust filter (AXII model only)  
SF-OPC6303-15-QN - Dust filter (AXIV model only)
- > 1756-K-EACH - Gas filter
- > 121-5866 - Pneumatic silencer

It is recommended that these filters be exchanged no less than annually. The filters should be monitored and inspected at regular intervals in new applications to gain an insight into how long the filters last before discolouration.

	<p><b>It should be noted that the frequency of filter exchanges may be affected by the application and location of the device.</b></p>
---	--

The dust filter (Figure 6-4) is located in the dust flow path between the outlet of the particulate sensor module and the inlet of the top particulate pump module. After completing the filter exchange it is important to again validate the heated inlet flow rate to ensure no leaks have been created during this process. The heated inlet flow rate is set to 2L/m  $\pm$  5%, as detailed in the [flow rate calibration](#) section below.

*Note: Instruments built after February 2024 do not require the NOx filter.*

The gas (Figure 6-3) and NOx filters (Figure 6-2) are located in the gas flow path, the gas filter is connected in line at the gas inlet, the NOx filter is connected in line just before the ozone sensor module (Air-MetER AX-3). Once these filters have been exchanged the flow rate of the gas path must be verified. The gas path flow rate should be 0.85L/m  $\pm$ 5%, this process is described in the [flow rate calibration](#) section (page 14).

*Note: Instruments built after February 2023 do not require the pneumatic silencer.*

The pneumatic silencer (Figure 6-5) is screwed into the enclosure at the bottom of the instrument in between the gas inlet and the gas/dust outlet. It can be removed by unscrewing it anti-clockwise and then replaced with the new silencer, being careful to ensure the O-ring does not fall off from the silencer.

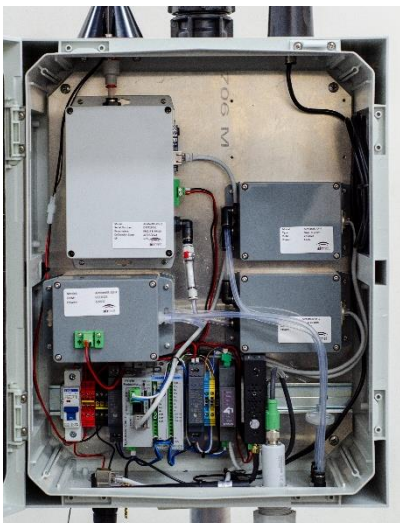

Figure 6-1 - Complete assembly  
(parts may vary)



Figure 6-2 - NOx Filter



Figure 6-3 - Gas Filter



Figure 6-4 - Dust Filter



Figure 6-5 - Pneumatic Silencer

## TSP HEAD CLEANING

A TSP head should be installed on all heated inlets at factory and need to be periodically cleaned when in the field. The time interval between cleaning varies depending on the application and location of the device. It is recommended to clean and check for any blockages within the TSP head and heated inlet assembly during annual routine maintenance.

This process may be completed using a brush and compressed air if available.



Figure 6-6 - TSP

## FLOW RATE CALIBRATION

### AXII FLOW RATE CALIBRATION

Attach a 0.4-5L/m rotameter (320-4A5) to the inlet of the AirMetER-AX, the flowmeter should indicate 2L/m  $\pm$  5%. Should this be out of tolerance, ensure there are no leaks and that there is pressure when blocking the heated inlet. Manual adjustment of the pump flow rate may be completed to achieve the flow rate as depicted below.

Unscrew 4x PH screws from the pump module top case (NOTE: these screws are retaining).

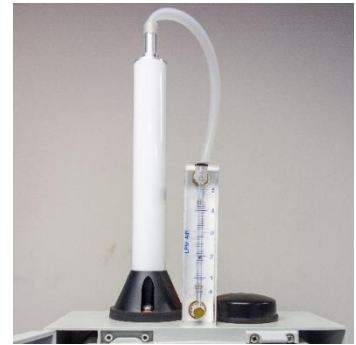

Figure 6-7 – Flowmeter

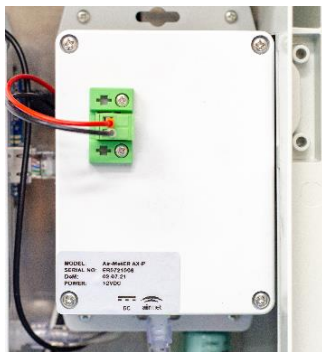

Figure 6-8 – Pump Top

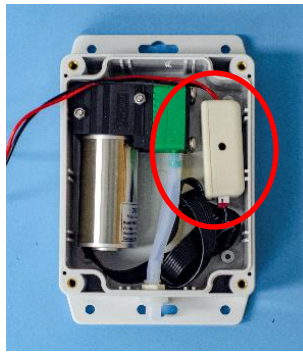

Figure 6-9 – Pump Internal

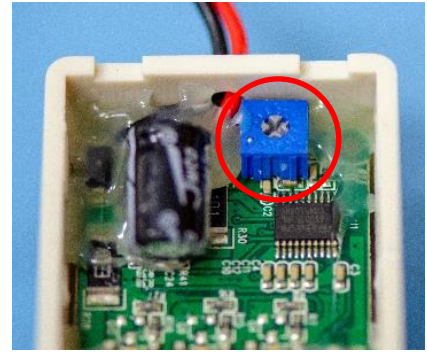

Figure 6-10 – Pump Control Internal

Using a small flat-blade driver, remove the lid from the control box within the pump module.

Adjust the potentiometer clockwise to increase the flowrate and anti-clockwise to decrease the flowrate in order to achieve 2L/m  $\pm$  5%.

In the event the flow rate cannot maintain 2L/m  $\pm$  5% at the inlet, losses can be diagnosed through-out the flow path: Heated inlet > particulate sensor module > dust filter > pump module > external exhaust

### AXIV FLOW RATE CALIBRATION

The flow rate is actively monitored and reported by the instrument in real-time. Should the flow rate deviate from the performance specification of 1L/m  $\pm$  5%, the device should be reviewed.

Clean the TSP inlet adaptor and heated inlet to clear any potential debris. Should this fail to rectify the flow rate readings, contact your local Air-Met Service department to organise further technical support.



AXII PARTICULATE SENSOR MODULE REMOVAL & REPLACEMENT

Equipment Required:

- PH screwdriver
- 2mm allen key
- Verified Rotameter capable of displaying 2L/m
- 3/8" flexible tubing

**WARNING:**

*Do not use a power drill on the particulate sensor module screws as this may cause damage to the instrument. Ensure that the AirMetER-AX is switched off and disconnected from any power source while removing and replacing the particulate sensor module.*

1. Remove the outlet tubing from the particulate sensor module by twisting the luer fitting anticlockwise.
2. Using a 2mm allen key, loosen the grub screw to ensure that the heated inlet can slide to assist with step 3.
3. Unplug the tube adaptor from the heated inlet by compressing the orange section inwards. This will release the tube adaptor. Slide the heated inlet upward until there is a gap between the heated inlet and tube adaptor.
4. Remove the four screws from the top and bottom of the particulate sensor module.
5. Unplug the ethernet and power supply cables from the particulate sensor module PCB.



Figure 6-11 – Luer Fitting



Figure 6-12 – TSP head

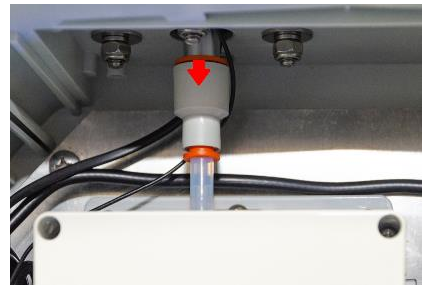

Figure 6-13 – Tube Adaptor

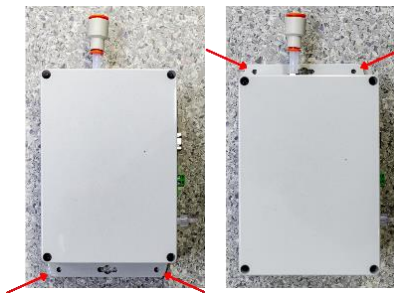

Figure 6-14 – Particulate Sensor Module Screws

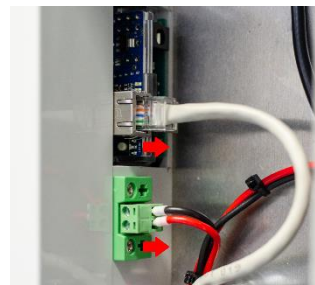

Figure 6-15 – Ethernet and Power Cables

When replacing the particulate sensor module, complete these steps in reverse.

To confirm that the instrument is not leaking after the particulate sensor module replacement, check that the flow rate is still within the required range before covering the inlet with a finger. If there is a build-up of pressure from blocking the end, the leak check has passed.



## AXIV PARTICULATE SENSOR MODULE REMOVAL & REPLACEMENT

### Equipment Required:

- PH screwdriver
- 2mm allen key
- Verified Rotameter capable of displaying 1L/m
- 3/8" flexible tubing

### WARNING:

*Do not use a power drill on the particulate sensor module screws as this may cause damage to the instrument. Ensure that the AirMetER-AX is switched off and disconnected from any power source while removing and replacing the particulate sensor module.*

1. Remove the outlet tubing from the particulate sensor module by twisting the luer fitting anticlockwise.
2. Using a 2mm allen key, loosen the grub screw to ensure that the heated inlet can slide to assist with step 3.
3. Unplug the tube adaptor from the heated inlet by compressing the orange section inwards. This will release the tube adaptor. Slide the heated inlet upward until there is a gap between the heated inlet and tube adaptor.
4. Remove the four screws from the top and bottom of the particulate sensor module.
5. Unplug the green molex connector from the base of the dust module.



Figure 6-16 – Luer Fitting



Figure 6-17 – TSP head

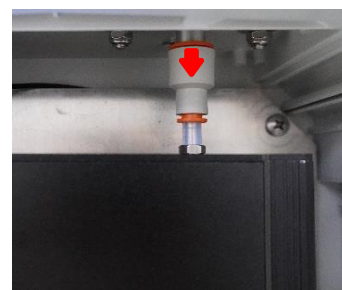

Figure 6-18 – Tube Adaptor



Figure 6-19 – Particulate Sensor Module Screws



Figure 6-20 – Green Molex Connector

When replacing the particulate sensor module, complete these steps in reverse.

To confirm that the instrument is not leaking after the particulate sensor module replacement, check that the flow rate is still within the required range before covering the inlet with a finger. If there is a build-up of pressure from blocking the end, the leak check has passed.

## HEATED INLET REMOVAL & REPLACEMENT

---

### Equipment Required:

- Verified Rotameter capable of displaying 0-2L/m
- 3/8" flexible tubing capable of connecting the heated inlet to the rotameter
- 2mm allen key
- Cabinet key



Figure 6-21 – Heated Inlet

1. Inside the AirMetER-AX unplug the heated inlet cable from the plug secured to the side of the enclosure.
2. Using a 2mm allen key loosen the grub screw to ensure the heated inlet can slide out of the tube adapter (the tube adapter is shown on the next slide).
3. Compress the orange section of the tube adapter and lift the heated inlet shaft away from the instrument to create a gap between the shaft and tube adapter.
4. Begin screwing the heated inlet anti-clockwise while using the other hand to assist the heated inlet cable to twist around the tube adapter, take care while screwing the heated inlet to not tangle the heated inlet cable as this may cause damage to the cable.
5. Once the inlet is unscrewed, pull the inlet and cable completely out of the adapter.
6. Bubble wrap the heated inlet adapter and TSP head before placing them within the instrument's enclosure ready for shipping.

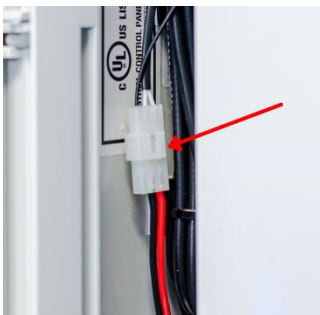

Figure 6-22 – Heated Inlet Cable

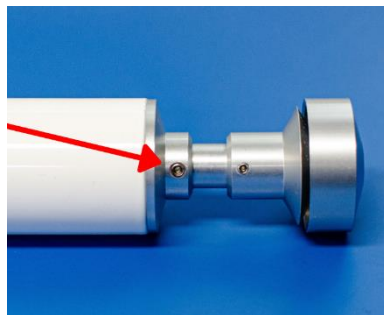

Figure 6-23 – Grub Screw

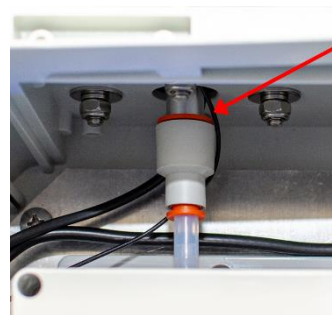

Figure 6-24 – Tube Adaptor

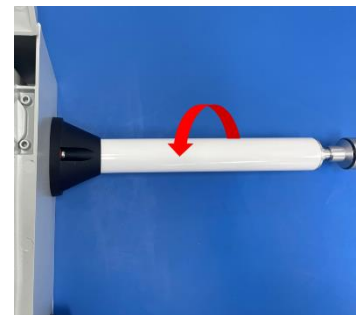

Figure 6-25 – Heated Inlet

## GAS MODULE CHECK

---

The gas readings of the AirMetER-AX should be checked on site by bump testing the instrument and verifying the readings on the LiveSense software.

The below table are recommendations only. Should you not have the recommended gas bottles, a suitable alternative should be sourced.

## CALIBRATION GAS RECOMMENDATION TABLE

---

DESCRIPTION	CALIBRATION GAS	DILUTION
Carbon Monoxide Sensor Module Low Range	100ppm CO	100
Carbon Monoxide Sensor Module High Range	100ppm CO from any 4-part gas bottle	N/A
Hydrogen Sulphide Sensor Module	25ppm H <sub>2</sub> S balance air	100
Ozone Sensor Module	Ozone generator (500ppb)	N/A
Nitric Oxide Sensor Module	10ppm NO	N/A
Oxygen Sensor Module	Fresh air (20.9% & 18%)	N/A
Nitrogen Dioxide Sensor Module Low Range	10ppm NO <sub>2</sub>	100
Nitrogen Dioxide Sensor Module High Range	10ppm NO <sub>2</sub>	N/A
Sulphur Dioxide Sensor Module	10ppm SO <sub>2</sub>	100
Carbon Dioxide Sensor Module	2.5% CO <sub>2</sub> (zero calibration must be completed using Nitrogen)	100
Photo Ionisation Sensor Module (VOC gases) Low Range	100ppm Isobutylene	100
Photo Ionisation Sensor Module (VOC gases) High Range	100ppm Isobutylene	N/A

## FREQUENCY TABLES

### CALIBRATION FREQUENCY TABLE

SENSOR TYPE	CALIBRATION FREQUENCY
Laser Particulate Sensor	Yearly
Sound/Noise Monitor	Yearly
Gas Sensor	6 months

### FILTER REPLACEMENT TABLE

FILTER DESCRIPTION	PART NUMBER	REPLACEMENT FREQUENCY
Dust Filter (AXII)	9933-05-CQ	Yearly*
Dust Filter (AXIV)	SF-OPC6303-15-QN	Yearly*
Gas Filter	17576-K-EACH	Yearly*
Pneumatic Silencer**	121-5866	Yearly*
NOx Filter for Air-MetER AX-3***	KAM-SF9	Yearly*

\* Dependent upon the application of the instrument.

\*\*Not required for instruments made after February 2023

\*\*\*Not required for instruments made after February 2024

### MODULE REPLACEMENT TABLE

MODULE DESCRIPTION	PART NUMBER	RECOMMENDED REPLACEMENT CYCLE
Particulate Sensor Module (PM <sub>1</sub> , PM <sub>2.5</sub> , PM <sub>4.25</sub> , PM <sub>10</sub> & TSP)	Air-MetER AX-IV	3 years
Particulate Sensor Module (PM <sub>2.5</sub> and PM <sub>10</sub> )	Air-MetER AX-11	2 years
Carbon Monoxide Sensor Module	Air-MetER AX-1 & Air-MetER AX-1H	2 years
Hydrogen Sulphide Sensor Module	Air-MetER AX-2 & Air-MetER AX-2H	2 years
Ozone Sensor Module	Air-MetER AX-3	2 years
Oxygen Sensor Module	Air-MetER AX-3H	2 years
Nitrogen Dioxide Sensor Module	Air-MetER AX-4 & Air-MetER AX-4H	2 years
Sulphur Dioxide Sensor Module	Air-MetER AX-5	2 years
Nitric Oxide Sensor Module	Air-MetER AX-6	2 years
Carbon Dioxide Sensor Module	Air-MetER AX-Q	5 years
Photo Ionisation Sensor Module (VOC gases)	Air-MetER AX-R & Air-MetER AX-RH	5 years
Noise Monitor Module	Air-MetER AX-N	N/A
Pump Module	Air-MetER AX-P	3 years

## ANNUAL CALIBRATION

---

In order for the Air-MetER AX-11 and Air-MetER AX-IV modules to be calibrated, it should be returned to the Air-Met Scientific Head Office in Melbourne. For a guide on how to remove the Air-MetER AX-11 module and all other modules, please refer to the [Module & Part Removal & Replacement](#) section.

Air-Met Service Facilities perform repair and part services, as well as calibrations and adjustments. Air-Met Scientific offers calibration reminder programs and maintenance contracts for the AirMetER-AX.

**For further details, please feel free to contact us at any of the following:**



Alternatively, scan the QR code to locate your nearest Air-Met Scientific office.



## 7. FIELD PARTICULATE MATTER K FACTOR ADJUSTMENT

---

Field calibration (K Factor Adjustment) of the AirMetER-AX is an important process to ensure data accuracy with respect to the location of the instrument. Field calibration should not be considered a substitute for factory calibration.

In order to perform a K Factor adjustment a gravimetric sample must be collected relative to the newly installed instrument.

**NOTE: Ensure correct methods for conducting a gravimetric sample are followed to ensure an accurate K Factor adjustment – If unsure regarding this process, please contact Air-Met Scientific.**

Provide collected data to Air-Met Scientific and a K Factor adjustment may be completed remotely.

## 8. SPARE PARTS & ACCESSORIES

---

PART NUMBER	DESCRIPTION
TF-TRI-AL	Tripod Mounting
AMS/250S/120B/15M/9C	120 Ah Lithium Solar Battery Kit
10085	TSP Head
10090	Heated Inlet
LPF-60-12-AUP	Power Supply (240V)
Air-MetER AX-IV	Particulate Sensor Module (PM <sub>1</sub> , PM <sub>2.5</sub> , PM <sub>4.25</sub> , PM <sub>10</sub> and TSP)
Air-MetER AX-11	Particulate Sensor Module (PM <sub>2.5</sub> and PM <sub>10</sub> )
Air-MetER AX-1	Carbon Monoxide Sensor Module Low Range
Air-MetER AX-1H	Carbon Monoxide Sensor Module High Range
Air-MetER AX-2	Hydrogen Sulphide Sensor Module Low Range
Air-MetER AX-2H	Hydrogen Sulphide Sensor Module High Range
Air-MetER AX-3	Ozone Sensor Module
Air-MetER AX-3H	Oxygen Sensor Module
Air-MetER AX-4	Nitrogen Dioxide Sensor Module Low Range
Air-MetER AX-4H	Nitrogen Dioxide Sensor Module High Range
Air-MetER AX-5	Sulphur Dioxide Sensor Module
Air-MetER AX-6	Nitric Oxide Sensor Module
Air-MetER AX-Q	Carbon Dioxide Sensor Module
Air-MetER AX-R	Photo Ionisation Sensor Module (VOC gases) Low Range
Air-MetER AX-RH	Photo Ionisation Sensor Module (VOC gases) High Range
Air-MetER AX-N	Noise Monitor Module
121-5866	Pneumatic Silencer
9933-05-CQ	Dust Filter (AXII)
SF-OPC6303-15-QN	Dust Filter (AXIV)
17576-K-EACH	Gas Filter
KAM-SF9	NOx Filter (for Air-MetER AX-3)
Contact Air-Met Scientific	Meteorological Sensors
Contact Air-Met Scientific	Black Carbon Sensor

## 9. SPECIFICATIONS

GENERAL	
Power Requirement	12VDC
Rated Power	43W maximum
Datalogging	3 years of logs onboard with unique file name creation every 24 hours
Alarm Indicator (optional)	Onboard dedicated alarm relay for all installed sensors
Operating Temperature	0°C to 50°C
Operating Humidity	0 to 95% non-condensing
Operating Pressure	860 to 1100hPa
Laser Module Operating Life	2 years (when operated below 40°C)

PARTICULATE MEASUREMENTS (Specifications are based on 20°C and 860 - 1100hPa conditions)		
	AirMetER-AXII (PM <sub>2.5</sub> & PM <sub>10</sub> )	AirMetER-AXIV (PM <sub>1</sub> , PM <sub>2.5</sub> , PM <sub>4.25</sub> , PM <sub>10</sub> and TSP)
Range	0-999.9µg/m <sup>3</sup>	0-30,000µg/m <sup>3</sup>
Resolution	0.1µg/m <sup>3</sup>	1µg/m <sup>3</sup>
Relative Error	Max of ±15% and ±10µg/m <sup>3</sup>	PM <sub>1</sub> /PM <sub>2.5</sub> /PM <sub>4.25</sub> ±10% of reading PM <sub>10</sub> ±15% of reading TSP ±20% of reading <span style="font-size: 2em; vertical-align: middle;">}</span> Up to 1000µg/m <sup>3</sup>

GAS MEASUREMENTS (Specifications are based on 20°C and 860 - 1200hPa conditions)			
Type	Range	Resolution	Min. Repeatable Detectable Level
CO (low range)	0-10ppm	1ppb	20ppb
CO (high range)	0-300ppm	1ppm	N/A
CO <sub>2</sub>	0-5000ppm	1ppm	15ppm
VOC (low range)	0-20ppm	1ppb	15ppb
VOC (high range)	0-200ppm	0.1ppm	N/A
SO <sub>2</sub>	0-10ppm	1ppb	20ppb
H <sub>2</sub> S (low range)	0-2ppm	1ppb	20ppb
H <sub>2</sub> S (high range)	0-100ppm	0.1ppm	N/A
NO <sub>2</sub> (low range)	0-1ppm	1ppb	20ppb
NO <sub>2</sub> (high range)	0-20ppm	0.1ppm	N/A
O <sub>3</sub>	0-1ppm	1ppb	20ppb
O <sub>2</sub>	0-25%VOL	0.1%VOL	N/A
NO	0-5ppm	1ppb	20ppb

Additional gases are available on request. Contact your local Air-Met Scientific office for more information.



WEATHER SENSOR	
Integrated climate sensor for weather monitoring	
Wind Speed	0 to 60.0 m/s
Wind Direction	0° to 360.0°
Air Temperature	-40.0 to +60.0°C
Relative Humidity	0 to 100.0%
Barometric Air Pressure	800.0 to 1060.0 hPa
Precipitation	0.00 to 100.00 mm/h

NOISE	
Integrated noise monitor using TA120	
Range	35.0 to 120.0 dB
Resolution	0° to 360.0°
Accuracy	According to IEC 61672-1 Class 1

COMMUNICATION	
PLC or SCADA Integration	Serial RS485
FTP Upload	Cellular, Ethernet or WiFi

ENCLOSURE	
Material	Polycarbonate
Dimensions	500mm (H) x 400mm (W) x 210mm (D)
Instrument Weight	15.0kg
Mounting Options	Pole-mount kit supplied (recommended installation method) Wall-mount ~70mm offset required for dust inlet clearance

# CONTACT INFORMATION

---

## AIR-MET SCIENTIFIC PTY LTD

### Head Office

7-11 Ceylon Street  
Nunawading VIC 3131  
Australia

### Postal Address

P.O. Box 133  
Nunawading VIC 3131  
Australia

Phone: 1800 000 744  
+61 3 8878 3300

Web: [www.airmet.com.au](http://www.airmet.com.au)  
Email: [sales@airmet.com.au](mailto:sales@airmet.com.au)

Air-Met Scientific Pty Ltd, Australia  
© 2024 Air-Met Scientific  
All rights reserved.